

Town of North Hampton
 FY16 Year-End Projects
 As of 10/15/16

| | <u>Project Balance</u> | <u>Paid in FY16</u> | <u>Encumbered</u> | <u>Paid in FY17</u> | <u>Remaining Balance</u> |
|--------------------------------------|------------------------|---------------------|-------------------|---------------------|--------------------------|
| NEW EMERGENCY GENERATOR INSTALLATION | \$ 49,585.00 | \$ 13,286.00 | \$ 36,299.00 | \$ 21,633.17 | \$ 14,665.83 (A) |
| PUBLIC WORKS GENERATOR INSTALLATION | \$ 4,150.00 | \$ - | \$ 4,150.00 | \$ - | \$ 4,150.00 (B) |
| DPW PROJECTS | \$ 127,197.00 | \$ 60,637.23 | \$ 66,559.77 | \$ 1,525.00 | \$ 65,034.77 (C) |
| POLICE DEPARTMENT | \$ 51,182.25 | \$ 48,736.61 | \$ 2,445.64 | \$ 2,196.66 | \$ 248.98 (D) |
| FIRE DEPARTMENT | \$ 31,174.04 | \$ 12,926.04 | \$ 18,248.00 | \$ - | \$ 18,248.00 (E) |
| DIGITAL MAILING SYSTEM | \$ 3,591.00 | \$ - | \$ 3,591.00 | \$ - | \$ 3,591.00 (F) |
| | \$ 266,879.29 | \$ 135,585.88 | \$ 131,293.41 | \$ 25,354.83 | \$ 105,938.58 |

(A) Monarch Electrical \$12,653.33, i,C Reed \$450, Sunbelt Rentals \$1,562.50

(B) Generator Connections \$2,200, Lamprey Energy \$1,950

(C) Bourassa Construction \$39,259.77, White's Welding \$5,000, Ross Bisplinghoff \$14,300, Lamprey Energy \$3,000, CCI Building Restoration \$3,475

(D) Tacticalgear.com \$248.98

(E) Bergeron Protective Clothing \$18,248

(F) Pitney Bowes \$3,591

Jim Maggiore, Chair
Larry Miller, Vice Chair
Rick Stanton, Member



Municipal Offices
233 Atlantic Avenue
North Hampton, NH 03862

Tel: (603) 964-8087
Fax: (603) 964-1514

TOWN OF NORTH HAMPTON, NEW HAMPSHIRE
THE SELECT BOARD

MOTIONS IN RE GENERATOR INSTALLATION ENCUMBRANCES

1. I move to encumber the sum of \$37,960.00 from the appropriation contained in Article 21 of the 2015 Warrant for the purpose of installing a generator at the Public Safety Building, pursuant to a contract with Monarch Electrical Service of Epping, New Hampshire dated June 23, 2016.
2. I move to encumber the sum of \$7,450.00 from the appropriation contained in Article 21 of the 2015 Warrant for the purpose of installing a generator at the Public Safety Building, pursuant to a contract with I.C. Reed & Sons of Raymond, New Hampshire dated June 22, 2016.
3. I move to encumber the sum of \$3,125.00 from the appropriation contained in Article 21 of the 2015 Warrant for the purpose of maintaining emergency electrical power during the installation a generator at the Public Safety Building, pursuant to a contract with Sunbelt Rentals of North Hampton, New Hampshire dated June 23, 2016.
4. I move to encumber the sum of \$1,050.00 from the appropriation contained in Article 21 of the 2015 Warrant for the purpose of installing a generator at the Public Safety Building, pursuant to a contract with Lamprey Energy of North Hampton, New Hampshire dated June 22, 2016.

\$13,286
DONE IN
F116

\$ 49,585 TOTAL
(13,286) F116

\$ 36,299 ENCUMBERED

RH Stanton
Jim Maggiore
Larry Miller
6-27-16

Jim Maggiore, Chair
Larry Miller, Vice Chair
Rick Stanton, Member



Municipal Offices
233 Atlantic Avenue
North Hampton, NH 03862

Tel: (603) 964-8087
Fax: (603) 964-1514

TOWN OF NORTH HAMPTON, NEW HAMPSHIRE
THE SELECT BOARD

MOTIONS IN RE GENERATOR INSTALLATION ENCUMBRANCES

1. I move to encumber the sum of \$37,960.00 from the appropriation contained in Article 21 of the 2015 Warrant for the purpose of installing a generator at the Public Safety Building, pursuant to a contract with Monarch Electrical Service of Epping, New Hampshire dated June 23, 2016.
2. I move to encumber the sum of \$7,450.00 from the appropriation contained in Article 21 of the 2015 Warrant for the purpose of installing a generator at the Public Safety Building, pursuant to a contract with I.C. Reed & Sons of Raymond, New Hampshire dated June 22, 2016.
3. I move to encumber the sum of \$3,125.00 from the appropriation contained in Article 21 of the 2015 Warrant for the purpose of maintaining emergency electrical power during the installation a generator at the Public Safety Building, pursuant to a contract with Sunbelt Rentals of North Hampton, New Hampshire dated June 23, 2016.
4. I move to encumber the sum of \$1,050.00 from the appropriation contained in Article 21 of the 2015 Warrant for the purpose of installing a generator at the Public Safety Building, pursuant to a contract with Lamprey Energy of North Hampton, New Hampshire dated June 22, 2016.

RH Stanton
Jim Maggiore
Larry Miller 6-27-16

KEVIN KELLEY
BUILDING INSPECTOR/CODE
ENFORCEMENT OFFICER
KKELLEY@NORTHHAMPTON-NH.GOV

TEL: (603) 964-8650

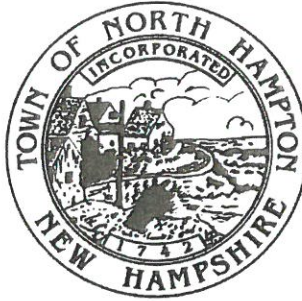

MUNICIPAL OFFICES
233 ATLANTIC AVENUE
NORTH HAMPTON, NH 03862

TEL: (603) 964-8650
FAX: (603) 964-1514

TOWN OF NORTH HAMPTON, NEW HAMPSHIRE
BUILDING INSPECTOR/CODE ENFORCEMENT/HEALTH OFFICER

Installation of 80KW Generator
233 Atlantic Ave
North Hampton NH 03862

To Town Administrator Paul Apple

Dear Paul,

The following are proposals to be encumbered through the Town's warrant article to install the new 80KW generator.

Please see individual scope of work

Monarch Electrical Service: \$37,960.00

I.C. Reed: \$ 7,450.00

Sunbelt Rentals: \$ 3,125.00

Lamprey Energy: \$ 1,050.00

Total \$ 49,585.00

There will be no charge from our electric utility (Eversource) as they are treating it as a new service.

If you have any questions or concerns please call or email this office directly.

Sincerely,

Kevin Kelley
Health Officer
Building Inspector
Code Enforcement Officer
Town of North Hampton
233 Atlantic Avenue
North Hampton NH 03862
(603) 964-8650 Office
(603) 964-1514 Fax



P O Box 446
Epping, NH 03042

(603) 734-5355
MonarchNH@yahoo.com

Proposal

Proposal Date: 6/23/2016

Proposal #: P033

Job:

To: Town of North Hampton
c/o Kevin Kelly
233 Atlantic Avenue
North Hampton, NH 03862-2352

Monarch Electric is pleased to present the following cost proposal for your approval.

Total

Job Description: 80 kw emergency back-up generator

Scope of Job:

- Proposed cost to complete the following work involved in the disconnect of the existing emergency generator and the tie-in of the new 80 kw generator
- Scope includes co-ordination with the Town of North Hampton Building Inspector, Kevin Kelly, to ensure the least amount of disruption in utility power to the Town Office building as well as temporary means to hook up owner's rental generator should it be necessary during a crisis situation
- Backfill and trenching by others
- Rigging of both generators and new secondary wire pulls to building by others
- Detailed breakdown of scope as shown on attached timeline schedule

Total Contract Value - \$37,960.00
(Thirty-seven thousand nine hundred sixty and 00/100 dollars)

37,960.00

Pricing is good for 30 days as of the date on this proposal

Respectfully Submitted,

Richard J. Tibbetts
Owner, Monarch Electric

CLIENT SIGNATURE _____



Proposal
I.C. REED & SONS, INC.
 8 EVANS DRIVE
 RAYMOND, NEW HAMPSHIRE 03077
 (603) 895-2731
 Fax: (603) 895-4831

E-Mail: ICReed Inc@aol.com

PROPOSAL SUBMITTED TO

Town of North Hampton

PHONE

(603) 964-8650

DATE

06/22/16

STREET

233 Atlantic Avenue

JOB NAME

Pulling Support

CITY, STATE AND ZIP CODE

North Hampton NH 03862

JOB LOCATION

Behind the Fire Station

ATTENTION

Kevin Kelley

DATE OF PLANS

Fax

We hereby submit proposal to:

Provide Labor, Equipment and Material to:

- Pull in 170 feet of (4) 500MCM cu. Conductors
- Pull in 170 feet of (1) 2/0 cu. Ground conductor (Possible substitute of 1/0 cu.)
- Leave coils on each end as discussed

- ***All conduit and junction boxes to be in place and completed beforehand.
- ***Measurment of conductors per Kevin Kelley

Price \$6,500

Possible second trip to remove old conductors once cut over - \$950 additional

We Propose hereby to furnish material and labor - complete in accordance with above specifications, for the sum of:

See above

Payment to be made as follows:

Valid P.O. authorizing work. Net 30 days upon completion. 1½% per month, 18% APR on overdue invoices.

All material is guaranteed to be as specified. All work to be completed in a workmanlike manner according to standard practices. Any alteration or deviation from above specifications involving extra costs will be executed only upon written orders, and will become an extra charge over and above the estimate. All agreements contingent upon strikes, accidents or delays beyond our control. Owner to carry fire, tornado and other necessary insurance. Our workers are fully covered by Workmen's Compensation Insurance.

Authorized
Signature _____

Note: This proposal may be withdrawn by us if not accepted within 30 days.

Acceptance of Proposal - The above prices, specifications and conditions are satisfactory and are hereby accepted. You are authorized to do the work as specified. Payment will be made as outlined above.

Signature _____

Date of Acceptance: _____

Signature _____



PC#: 510
 170 LAFAYETTE RD
 NORTH HAMPTON, NH 03862
 603-964-5422

SUNBELT RENTALS, INC.

Salesman: 51000 PORTSMOUTH HOUSE ACC
 Typed By: MSPORDER

Job Site:

TOWN OF NORTH HAMPTON-HIGHWAY
 10 HAMPTON AIR FIELD
 NORTH HAMPTON, NH 03862

C#: 603-964-6442 J#: 603-396-6778

Customer: 4041534

TOWN OF NORTH HAMPTON-HIGHWAY
 P O BOX 710
 233 A ATLANTIC AVE
 NORTH HAMPTON, NH 03862

QUOTE



Contract #.. 61286912
 Contract dt. 6/23/16
 Date out.... 6/27/16 8:00 AM
 Est return.. 7/25/16 8:00 AM
 Job Loc..... 10 HAMPTON AIR FIELD, NORTH HAMP
 Job No..... 1 - TOWN OF NORTH HA
 P.O. #.....
 Ordered By.. KELLEY, KEVIN
 NET DUE UPON RECEIPT

| QTY | EQUIPMENT # | Min | Day | Week | 4 Week | Amount |
|-----------------|----------------------------------|--------------------|--------|------------|---------|---------|
| 1.00 | 20KW DIESEL GENERATOR 0090030 | 215.00 | 215.00 | 495.00 | 1090.00 | 1090.00 |
| 1.00 | 50' #2 BANDED 5-WIRE | 25.00 | 25.00 | 45.00 | 125.00 | 125.00 |
| 1.00 | #2 BANDED 5-WIRE MALE TAIL | 14.00 | 14.00 | 25.00 | 60.00 | 60.00 |
| 1.00 | #2 BANDED 5-WIRE FEMALE TAIL | 14.00 | 14.00 | 25.00 | 60.00 | 60.00 |
| *** EQP MSG *** | | | | | | |
| 8 | Hrs/Day 40 | Hrs/Wk = 1.0x Rate | | | | |
| 9-16 | Hrs/Day 41-80 | Hrs/Wk = 1.5x Rate | | | | |
| 17+ | Hrs/Day 81+ | Hrs/Wk = 2.0x Rate | | | | |
| SALES ITEMS: | | | | | | |
| Qty | Item number | Unit | Price | | | |
| 1 | ENVIRONMENTAL | EA | 27.250 | | | |
| | ENVIRONMENTAL | | | | | |
| | RENTAL PROTECTION PLAN | | | 27.25 | | |
| | | | | 200.25 | | |
| | 208v three phase- standby | | | | | |
| | | | | Sub-total: | 1562.50 | |
| | | | | Total: | 1562.50 | |

IF THE EQUIPMENT DOES NOT WORK PROPERLY, NOTIFY THE OFFICE AT ONCE

Rate your rental experience www.sunbeltrentals.com/survey

MULTIPLE SHIFTS OR OVERTIME RATES MAY APPLY

CUSTOMER IS RESPONSIBLE FOR REFUELING, DAMAGES AND REPAIRS

- The total charges are an estimate based on the estimated rental period and other information provided by Customer.
- Customer assumes all risks associated with the Equipment during the Rental Period, including injury and damage to persons, property and the Equipment.
- Customer is responsible for and shall only permit properly trained, Authorized Individuals to use the Equipment.
- If the Equipment does not operate properly, is not suitable for Customer's intended use, does not have operating and safety instructions or Customer has any questions regarding use of the Equipment, Customer shall not use the Equipment and shall contact Sunbelt immediately.
- Equipment misuse or using damaged or malfunctioning Equipment may result in serious bodily injury or death and Customer agrees that Customer (i) assumes all risk associated thereunder, and (ii) indemnifies Sunbelt Entities for all claims or damages as a result of misuse or use of damaged or malfunctioning Equipment.
- Customer has received, read, understands and agrees to the estimated charges and all the terms on this page, plus all sections on the reverse side of this Contract ("Sections"), including Release and Indemnification in Section 8 and Environmental Fee in Section 16, which can also be found at www.sunbeltrentals.com/rentalcontract. *Delivery/Pickup Surcharge fee explanation is available at www.sunbeltrentals.com/surcharge.
- Customer must contact Sunbelt to request pickup of Equipment, retain the Pick-Up Number given by Sunbelt and will be responsible for Equipment until actually retrieved by Sunbelt.
- Customer waives its right to a jury trial in any dispute as set forth in Section 19.
- At the election of Sunbelt or Customer, Customer agrees to submit every dispute to arbitration and waives any right to bring a class action as set forth in Section 20.

for its becoming Rental Protection Plan (see Reverse Side for details) _____ (Customer initials)

Continued on the next page...

6/22/16

Town of North Hampton
233 Atlantic Avenue
North Hampton, NH 03862
Att. Kevin Kelly

A New Generator Installation:

We will disconnect the existing generator from the gas piping

We will lift the existing generator and load it on our truck for transportation

We will set the new generator in place using our crane truck

We will install new black iron piping including drip leg, stainless steel vibration connection and regulator.

We will modify the exiting piping so the piping is low to the ground.

We will do a pressure check and make sure any adjustments are made to provide the gas pressure specified by the generator manufacturer.

Parts and Labor \$1,050.00

North Hampton: _____

Lamprey Energy: _____



21 Blake Road
Epping, NH 03042

Ph: 603-734-5355
Fax: 603-734-4022
Email: monarchnh@yahoo.com

Project *North Hampton - TNH*

By: *[Signature]*

Title

Scale

Project # *16211*

Sheet

#

Date *6/6/16*

000000

| Task Description | Start Date | End Date | Status |
|---|------------|----------|--------|
| MES = Manurech Electric | | | |
| TNH = Town of North Hampton | | | |
| 80 EV SPD 4 wires | | | |
| Change over week ending 12/19 | 12/19 | 12/26 | DONE |
| ← LA M PLY - DONE | | | |
| ← I C 1200 | | | |
| ← Hanging New Socket / ATS - MES - | | | |
| ← MODERN elect DONE | | | |
| ← REMOVE EXISTING Socket - TNH - | | | |
| Generator Connection - HIGH CUR SKED | | | |
| Set NEW GEN Set - TNH - | | | |
| SUB SECT - Generator DONE | | | |
| Cut over existing 3 wires - MES + CO. - | | | |
| to new 4-wires | | | |
| Prep New Raceways - MES - | | | |
| Get connection to generator - TNH - | | | |
| Generator Start up and Test - TNH - | | | |

Jim Maggiore, Chair
Larry Miller, Vice Chair
Rick Stanton, Member

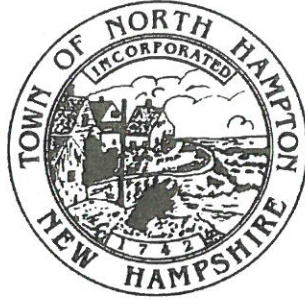

Municipal Offices
233 Atlantic Avenue
North Hampton, NH 03862

Tel: (603) 964-8087
Fax: (603) 964-1514

TOWN OF NORTH HAMPTON, NEW HAMPSHIRE
THE SELECT BOARD

MOTIONS IN RE INTRA LINE TRANSFERS

1. I move to make the transfers summarized on the attached exhibit for the purpose of encumbering funds in the FY 2016 Operating Budget.

RH Stanton
Jim Maggiore
in Miller 6-27-16

approved
3-0
6/27/16

TOWN OF NORTH HAMPTON
RESERVE FOR ENCUMBRANCES
FY2016

| Item | Transfer | From | To | Balance to Encumber |
|---|--------------|--|--|-------------------------------------|
| WARRANT ARTICLES: | | | | |
| Emergency Generator | \$ - | N/A | 01-4902-16-021 Emergency Generator | \$ 36,299.00 Balance \$39,635.00 ✓ |
| Subtotal | \$ - | | | \$ 36,299.00 |
| ADMINISTRATION: | | | | |
| Postage Machine | \$ 2,646.00 | 01-4140-10-131 TC/TX Assistant Salary | 01-4140-10-740 TC/TX Equipment | \$ 3,591.00 Balance \$945.00 ✓ |
| Subtotal | \$ 2,646.00 | | | \$ 3,591.00 |
| BUILDING MAINTENANCE: | | | | |
| Library Roof Ventilation | \$ 68,388.28 | 01-4210-10-210 PD Health Insurance | 01-4194-10-580 GB Building Maintenance | \$ 2,800.00 Overspent \$(65,588.28) |
| Install Highway Shed Generator | \$ 4,150.00 | 01-4220-10-210 FD Health Insurance | 01-4194-10-580 GB Building Maintenance | \$ 4,150.00 Overspent \$(65,588.28) |
| Library Parking Area - Clerks Driveway | \$ 2,245.12 | 01-4210-10-210 PD Health Insurance | 01-4194-10-580 GB Building Maintenance | \$ 2,245.12 Overspent \$(65,588.28) |
| Extend office space for equipment storage | \$ 6,300.00 | 01-4220-10-210 FD Health Insurance | 01-4194-10-580 GB Building Maintenance | \$ 6,300.00 Overspent \$(65,588.28) |
| Propane heater for new office space | \$ 3,000.00 | 01-4210-10-210 PD Health Insurance | 01-4194-10-580 GB Building Maintenance | \$ 3,000.00 Overspent \$(65,588.28) |
| Subtotal | \$ 84,083.40 | | | \$ 18,495.12 ✓ |
| CEMETERY: | | | | |
| Replace Center Cemetery Shed Roof | \$ 1,724.30 | 01-4332-00-414 Distribution Costs - Hydrants | 01-4195-10-630 CEM General Maintenance | \$ 2,200.00 Balance \$475.70 |
| Center Cemetery Pvmnt Maint | \$ 8,200.00 | 01-4332-00-414 Distribution Costs - Hydrants | 01-4195-10-630 CEM General Maintenance | \$ 8,200.00 Balance \$475.70 |
| Subtotal | \$ 9,924.30 | | | \$ 10,400.00 ✓ |

50/50 SPLIT

Jim Maggiore, Chair
Larry Miller, Vice Chair
Rick Stanton, Member



Municipal Offices
233 Atlantic Avenue
North Hampton, NH 03862

Tel: (603) 964-8087
Fax: (603) 964-1514

TOWN OF NORTH HAMPTON, NEW HAMPSHIRE
THE SELECT BOARD

MOTIONS IN RE TOWN CLERK PROJECTS

1. I move to encumber the sum of \$3,591.00 from the FY 2016 Operating Budget for the purpose of upgrading a digital mailing system and associated items, pursuant to a contract with Pitney Bowles, a national company, dated June 1, 2016.

\$ 3,591 ENCUMBERED

RT Stanton

Jim Maggiore

John Miller

6-27-16

OTHER: ADMINISTRATION

pitneybowes

Purchase Quote/Equipment and Software Maintenance Quote

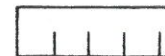

Agreement

Your Business Information

TOWN OF NORTH HAMPTON

| | |
|---|------------------------------|
| Full Legal Name of Client / DBA Name of Client | Tax ID # (FEIN/TIN) |
| 233 ATLANTIC AVE FL 2 | NH 0 |
| Billing Address : Street | City |
| | State |
| Susan Buchanan | 6039648087 |
| Billing Contact Name | Billing Contact Phone # |
| | Billing Account # |
| 233 ATLANTIC AVE FL 2 | NH 0 |
| Installation Address (if different from billing address) : Street | City |
| | State |
| Susan Buchanan | 6039648087 |
| Installation Contact Name | Installation Contact Phone # |
| | Installation Account # |
| | 2016-09-05 |
| PO # | Quote Expiration Date |

Your Business Needs

| Qty | Item | Business Solution Description | Sales Type | Price |
|-----|--------|--|------------|------------|
| 1 | DM400C | DM400C Digital Mailing System | PURCHASE | \$ 0.00 |
| 1 | 1FAE | Basic Accounting -50 Accounts | PURCHASE | \$ 0.00 |
| 1 | 1FY9 | DM400 70 LPM | PURCHASE | \$ 0.00 |
| 1 | 1GW5 | 5lb Integrated Weighing Feature | PURCHASE | \$ 949.20 |
| 1 | G900 | Meter for DM300/DM400/475 Series | RENT | \$ 66.00 |
| 1 | G9SS | USPS Tracking Services Activation | RENT | \$ 0.00 |
| 1 | MP9G | Integrated Weighing Platform | PURCHASE | \$ 0.00 |
| 1 | SBTA | DM400C Digital Meter System | PURCHASE | \$ 2,641.8 |
| 1 | SJ40 | SoftGuard for DM400 | RENT | \$ 7.00 |
| 1 | STDSLA | Standard SLA-Equipment Service Agreement (for DM400C Digital Mailing System) | SLA | \$ 446.00 |

| | |
|------------------|-------------|
| Purchase Total** | \$ 3,591.00 |
| Monthly Total** | \$ 73.00 |
| Annual Total** | \$ 446.00 |

**Plus applicable taxes which will be applied at the time of purchase.

Jim Maggiore, Chair
Larry Miller, Vice Chair
Rick Stanton, Member



Municipal Offices
233 Atlantic Avenue
North Hampton, NH 03862

Tel: (603) 964-8087
Fax: (603) 964-1514

TOWN OF NORTH HAMPTON, NEW HAMPSHIRE
THE SELECT BOARD

MOTIONS IN RE INSTALLTION

1. I move to encumber the sum of \$2,200.00 from the FY 2016 Operating Budget for the purpose of installing the old Public Safety Generator at the Department of Public Works Building, pursuant to a contract with Generator Connection, Inc., of Barrington, New Hampshire dated June 22, 2016.
2. I move to encumber the sum of \$1,950.00 from the FY 2016 Operating Budget for the purpose of installing the old Public Safety Generator at the Department of Public Works Building, pursuant to a contract with Lamprey Energy of North Hampton, New Hampshire, dated June 22, 2016.

\$ 4,150 ENCUMBERED

RH Stanton
Jim Maggiore
Larry Miller 6.27-16

Jim Maggiore, Chair
Larry Miller, Vice Chair
Rick Stanton, Member

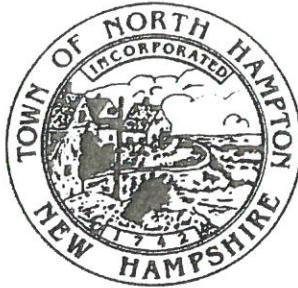

Municipal Offices
233 Atlantic Avenue
North Hampton, NH 03862

Tel: (603) 964-8087
Fax: (603) 964-1514

TOWN OF NORTH HAMPTON, NEW HAMPSHIRE
THE SELECT BOARD

MOTIONS IN RE INSTALLTION

1. I move to encumber the sum of \$2,200.00 from the FY 2016 Operating Budget for the purpose of installing the old Public Safety Generator at the Department of Public Works Building, pursuant to a contract with Generator Connection, Inc., of Barrington, New Hampshire dated June 22, 2016.
2. I move to encumber the sum of \$1,950.00 from the FY 2016 Operating Budget for the purpose of installing the old Public Safety Generator at the Department of Public Works Building, pursuant to a contract with Lamprey Energy of North Hampton, New Hampshire, dated June 22, 2016.

RH Stanton
Jim Maggiore
Larry Miller 6-27-16

KEVIN KELLEY
BUILDING INSPECTOR/CODE
ENFORCEMENT OFFICER
KKELLEY@NORTHHAMPTON-NH.GOV

TEL: (603) 964-8650



MUNICIPAL OFFICES
233 ATLANTIC AVENUE
NORTH HAMPTON, NH 03862

TEL: (603) 964-8650
FAX: (603) 964-1514

TOWN OF NORTH HAMPTON, NEW HAMPSHIRE
BUILDING INSPECTOR/CODE ENFORCEMENT/HEALTH OFFICER

Installation of 15KW Generator
10 Airport Rd
Highway Department
North Hampton NH 03862

To Town Administrator Paul Apple

Dear Paul,

The following are proposals to be encumbered through the Town's warrant article to install the 15KW generator.

Please see individual scope of work

Generator Connection: \$ 2,200.00

* amprey Energy: \$ 1,950.00

Total \$ 4,150.00

If you have any questions or concerns please call or email this office directly.

Sincerely,

Kevin Kelley
Health Officer
Building Inspector
Code Enforcement Officer
Town of North Hampton
233 Atlantic Avenue
North Hampton NH 03862
(603) 964-8650 Office
(603) 964-1514 Fax

PROPOSAL

The Generator Connection, Inc
P.O. Box 471
Barrington, NH 03825
(603) 664-4004 Fax (603) 905-9025

| | | |
|---|--------------------------|------------------------|
| PROPOSAL SUBMITTED TO Town of North Hampton | PHONE 608-9489 | DATE 6-22-16 |
| STREET 233 Atlantic Ave | JOB NAME | |
| CITY, STATE and ZIP CODE No. Hampton, NH, 03862 | JOB LOCATION | |
| ARCHITECT | DATE OF PLANS | JOB PHONE |
| ATTN: KEVIN KELLY | | |

We hereby submit specifications and estimates for:

Disconnect 100 amp Automatic Transfer Switch and Rewire Circuits at Town Office.

Install 100 amp. Automatic Transfer Switch and 24 Circuit Sub Panel at Public Works Building and wire Relocated 15 kw standby Generator. Final Test Included

We Propose hereby to furnish material and labor — complete in accordance with above specifications, for the sum of:

Twenty Two Hundred _____ dollars (\$ **2,200.00**)

Payment to be made as follows:

Payment Due Upon Completion of Proposal.

All material is guaranteed to be as specified. All work to be completed in a workmanlike manner according to standard practices. Any alteration or deviation from above specifications involving extra costs will be executed only upon written orders, and will become an extra charge over and above the estimate. All agreements contingent upon strikes, accidents or delays beyond our control. Owner to carry fire, tornado and other necessary insurance. Our workers are fully covered by Workman's Compensation Insurance.

Authorized Signature _____

Wayne Wayne

Note: This proposal may be withdrawn by us if not accepted within **- 30 -** days.

Acceptance of Proposal — The above prices, specifications and conditions are satisfactory and are hereby accepted. You are authorized to do the work as specified. Payment will be made as outlined above.

Signature _____

Signature _____

Date of Acceptance: _____

Town of North Hampton
233 Atlantic Avenue
North Hampton, NH 03862
Att. Kevin Kelly

6/22/16

B Existing Generator Installation (Department of Public Works):

Any concrete pad preparation, trenching and finish landscaping is the responsibility of the Town of North Hampton and has not been included in this proposal.

We will provide and set a concrete pad for the generator (45" wide x 86" long by 5 1/2" thick)

We will deliver the generator to the Public Works Garage

We will set the generator in place on the new concrete pad, using our crane truck

We will disconnect the piping after the natural gas meter and install a T to go to the generator. We will run black iron piping along the foundation of the building to the trench that goes from the building to the generator.

We will install two hard sweeps and underground gas line from the building to the generator. This will be buried once completed.

We will install black iron piping including a drip leg, stainless steel vibration connection and regulator.

We will do a pressure check and make sure any adjustments are made to provide the gas pressure specified by the generator manufacturer.

Parts and Labor \$1,950.00

North Hampton: _____

Lamprey Energy: _____



Jim Maggiore, Chair
Larry Miller, Vice Chair
Rick Stanton, Member

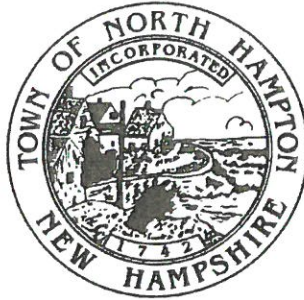

Municipal Offices
233 Atlantic Avenue
North Hampton, NH 03862

Tel: (603) 964-8087
Fax: (603) 964-1514

TOWN OF NORTH HAMPTON, NEW HAMPSHIRE
THE SELECT BOARD

MOTIONS IN RE DPW PROJECTS

- x 1. I move to encumber the sum of \$12,300.00 from the FY 2016 Operating Budget for the purpose of replacing a culvert on North Road, pursuant to a contract with Bourassa Construction, LLC of Stratham, New Hampshire July 31, 2014.
- \$31,985.35
DONE
IN JUNE 2. I move to encumber the sum of \$48,500.00 from the FY 2016 Operating Budget for the purpose of paving Old Locke Road and Causeway Road, pursuant to a contract with Bourassa Construction, LLC of Stratham, New Hampshire July 31, 2014.
- x 3. I move to encumber the sum of \$5,000.00 from the FY 2016 Operating Budget for the purpose of installing a shoulder attachment on Causeway Road, pursuant to a contract with White's Welding Company, Inc. of Hampton, New Hampshire, dated June 27, 2016.
- x 4. I move to encumber the sum of \$17,300.00 from the FY 2016 Operating Budget for the purpose of installing a bunk room and shower at the Highway Garage, extending office space therein for equipment storage and adding a propane heater for new space, pursuant to contracts with Russ Bissplinghoff, of North Hampton, New Hampshire, in the amount of \$14,300, dated June 27, 2016 and Lamprey Energy of North Hampton, New Hampshire, in the amount of \$3,000, dated June 27, 2016.
5. I move to encumber the sum of \$997.00 from the FY 2016 Operating Budget for the purpose of purchasing software to track vehicle maintenance, pursuant to a contract with PC Help Limited, of Las Vegas, Nevada, dated August June 27, 2016.
PURCHASED
IN
JUNE ✓
- y 6. I move to encumber the sum of \$2,800.00 from the FY 2016 Operating Budget for the purpose of purchasing a Library attic fan, pursuant to a contract with CCI Building Restoration and Waterproofing, Inc. of North Hampton, New Hampshire, dated August 11, 2015.
- \$27,654.88
DONE IN
JUNE ✓ 7. I move to encumber the sum of \$29,900.00 from the FY 2016 Operating Budget for the purpose of repaving the Library Parking Lot, pursuant to a contract with Bourassa Construction, LLC of Stratham, New Hampshire July 31, 2014.

8. I move to encumber the sum of \$2,200.00 from the FY 2016 Operating Budget for the purpose of replacing the Cemetery Shed Roof, pursuant to a contract with CCI Building Restoration and Waterproofing, Inc. of North Hampton, New Hampshire, dated June 10, 2016.
9. I move to encumber the sum of \$8,200.00 from the FY 2016 Operating Budget for the purpose of repaving the Cemetery paths, pursuant to a contract with Bourassa Construction, LLC of Stratham, New Hampshire July 31, 2014.

RH Strath

Jim Maggione

by [signature] 6-27-16

\$ 127,197.00 TOTAL

(60,637.23) FY16

\$ 66,559.77 ENCUMBRANCES

North Hampton Public Works
Project Priority List
6/27/16

| Item | Units | | Unit Price | = | Total | |
|--|-------|-----|------------------------------|---|---------------------------------|----------------------------------|
| A. Highway Department | | | | | | |
| 1. North Road Culvert Replacement 36" Culvert Replacement with headwalls | 1.00 | LS | 12,300.00 | = | 12,300.00 | |
| 2. Old Locke Rd. Project Replace drainage pipe, regrade swale and driveway Install a 1 1/2" overlay to roadway | 1.00 | LS | 43,500.00 | = | 43,500.00 | |
| 3. Causeway Rd. 1 1/2" Ave. overlay | 1.00 | LS | 5,000.00 | = | 5,000.00 | |
| 4. Build Shoulder Attachment | 1.00 | LS | 5,000.00 | = | 5,000.00 | |
| 5. Install Bunk Room and Shower- Highway Garage | 1.00 | LS | 10,000.00 | = | 10,000.00 | |
| 6. Purchase and Implement Equip. Maint. Program | 1.00 | LS | 997.00 | = | 997.00 | |
| | | | Total Highway | = | 76,797.00 | 76,797.00 |
| B. Building Maintenance | | | | | | |
| 1. Library Roof Ventilation | 1.00 | LS | 2,800.00 | = | 2,800.00 | |
| 2. Install Highway Shed Generator | 1.00 | LS | 5,000.00 4,150 | = | 5,000.00 4,150.00 | |
| 3. Library Parking Area- Clerks Driveway Paving | 1.00 | LS | 30000.00 | = | 30,000.00 | |
| 4. Extend office space for equipment storage | 1.00 | LS | 6000.00 | = | 6,000.00 | |
| 5. Propane heater for new office space | 1.00 | LS | 3000.00 | = | 3,000.00 | |
| | | | Total Buildings | = | \$46,800.00 | \$46,800.00 45,950 |
| C. Cemetery Department | | | | | | |
| 1. Replace Center Cemetery Shed Roof | 1.00 | LS | 2,000.00 | = | 2,000.00 | |
| 2. 2" Ave. Overlay- Center Cemetery Pvmt Maint. Phase 1 of a 6 Phase Program | 82.00 | Ton | 100.00 | = | 8,200.00 | |
| | | | Total Cemetery | = | \$10,200.00 | \$10,200.00 |
| | | | Total Projects | = | \$133,7 | |

132,947.00

Item # A-1

North Road Culvert Repacement

Paving Estimate- Phase 1

6/24/2016

| Item | Units | | Unit Price | | Total |
|-------------------------|-------|----|---------------|---|----------|
| 1. Excavator rental | 24.00 | LS | 95.00 | = | 2280.00 |
| 2. Crushed Stone | 24.00 | Tn | 12.00 | = | 288.00 |
| 3. 36" HDPE Pipe- 40 LF | 1.00 | Ea | 1182.01 | = | 1182.01 |
| 4. Concrete Headwalls | 2.00 | Ea | 2000.00 | = | 4000.00 |
| 5. Hand Pave | 10.00 | Tn | 124.00 | = | 1240.00 |
| 6. Guard Rail | 1.00 | Ea | 3300.00 | = | 3300.00 |
| | | | | | |
| | | | Project Total | = | 12290.01 |

| | | | | |
|--|--------------|-----|------------------------|----------------------|
| Item# A2 & A3 | | | | |
| North Hampton Public Works | | | | |
| 15-16 Road Maintenance Projects- Budget | | | | |
| 7/1/15 | | | | |
| C. Old Locke/ Causeway Road | | | | |
| Item | Units | | Unit Price | Total |
| 1. Mobilization/ Cold Plane Transitions | 1.00 | LS | 1500.00 | = 1500.00 |
| 2. 1 1/2" Average Overlay | 450.00 | Ton | 72.50 | = 32625.00 |
| 3. Crushed Gravel Shoulders | 3200.00 | LF | 0.75 | = 2400.00 |
| 4. Bituminous Concrete Handwork | 40.00 | Ton | 124.00 | = 4960.00 |
| 5. Drainage | 1.00 | LS | 7000.00 | = 7000.00 |
| | | | Total Old Locke | = \$48,485.00 |

Bourassa Construction, LL, 145 Union Rd, Stratham, NH 03885

PROPOSAL

Date: July 29, 2014

To: Town of North Hampton
Public Works Facility
10 Airport Road
North Hampton, NH 03862

Paving Projects: 2014-2015

| | Estimated Units | Unit Bid Price | Extended Bid Price | |
|---|-----------------|----------------|--------------------------------------|----------------------|
| A. North Road (Post Rd to Rte 1) | | | | |
| 1. Install bituminous concrete shim (NH 3/8" top) (tons) | 500 | \$ 73.50 | \$ 36,750.00 | |
| 2. Install an average 1-1/2" top surface course (NH 1/2" Top) (tons) | 1,300 | \$ 72.50 | \$ 94,250.00 | |
| 3. Bituminous concrete handwork; driveway approaches, trench patch (tons) | 60 | \$ 124.00 | \$ 7,440.00 | |
| 4. Install an average of 2' crushed gravel shoulders to roadway (LF) | 12,000 | \$ 0.75 | \$ 9,000.00 | |
| 5. Mobilization, cold plane transitions and construction signage for project. Lump Sum (unit) | 1 | \$ 500.00 | \$ 500.00 | |
| | | | North Road Total | \$ 147,940.00 |
| B. Willow Ave./Causeway Rd. | | | | |
| 1. Reclaim approx. 1400 LF of existing pavement, rough grade surplus material on existing roadway, fine grade and compact | 5,800 | \$ 2.34 | \$ 13,572.00 | |
| 2. Install a 2" bituminous concrete base course to roadway (tons) | 670 | \$ 70.00 | \$ 46,900.00 | |
| 3. Install a 1-1/2" top surface course to roadway (tons) | 560 | \$ 72.50 | \$ 40,600.00 | |
| 4. Bituminous concrete handwork; driveway approaches (tons) | 20 | \$ 124.00 | \$ 2,480.00 | |
| 5. Install an average of 2' crushed gravel shoulders to roadway (LF) | 4,600 | \$ 0.75 | \$ 3,450.00 | |
| 6. Mobilization, project clean up, and construction signage for project. Lump Sum (unit) | 1 | \$ 500.00 | \$ 500.00 | |
| | | | Willow Ave./Causeway Rd Total | \$ 107,502.00 |
| C. River Road | | | | |
| 1. Install an average 1-1/2" top surface course to roadway (tons) | 260 | \$ 72.50 | \$ 18,850.00 | |
| 2. Install an average of 2' crushed gravel shoulders to roadways (LF) | 2,000 | \$ 0.75 | \$ 1,500.00 | |
| 3. Bituminous concrete handwork; driveway approaches (tons) | 20 | \$ 124.00 | \$ 2,480.00 | |
| | | | River Road Total | \$ 22,830.00 |
| D. Old Locke Road | | | | |
| 1. Install an average 1-1/2" top surface course to roadway (tons) | 450 | \$ 72.50 | \$ 32,625.00 | |
| 2. Install an average of 2' crushed gravel shoulders to roadways (LF) | 3,600 | \$ 0.75 | \$ 2,700.00 | |
| 3. Bituminous concrete handwork; driveway approaches (tons) | 50 | \$ 124.00 | \$ 6,200.00 | |
| 4. Mobilization, cold plane transitions, and construction signage for project. Lump Sum (unit) | 1 | \$ 500.00 | \$ 500.00 | |
| | | | Old Locke Road Total | \$ 42,025.00 |
| | | | Project Grand Total | \$ 320,297.00 |

Notes:

- A. Crushed gravel or loam required for shoulders will be furnished by the Town of North Hampton
- B. Apply bituminous tack coat prior to overlays

TOWN OF NORTH HAMPTON

Signature: *[Signature]*
 Title: Town Administrator, duly authorized
 Date: July 28, 2014
July 31, 2014

ACCEPTANCE OF PROPOSAL

BOURASSA CONSTRUCTION, LLC

Signature: *[Signature]*
 Name/Title: Gary Bourassa - Owner
 Date: 7/29/2014

Town of North Hampton

PURCHASE ORDER

233 Atlantic Avenue
North Hampton, NH 03862
Tel. 603.964.8087
Fax 603.964.1514

The following number must appear on all related correspondence,
shipping papers, and invoices: P.O. NUMBER: PW14038

To: **Bourassa Construction LLC**
145 Union Road

Stratham, NH 03885

| P.O. DATE | REQUISITIONER | SHIP VIA | F.O.B. POINT | TERMS |
|-----------|---------------|----------|--------------|-------|
| 7/31/14 | | | 14-15 Paving | |

| QTY | UNIT | DESCRIPTION | UNIT PRICE | TOTAL |
|-------|------|------------------------------|---------------------|-------|
| 5800 | SY | Reclaim/Grade | 2.34 | |
| 670 | Tn | Machine pave 2" base | 70.00 | |
| 150 | Tn | Handpave | 124.00 | |
| 2570 | Tn | Machine Pave: 1 1/2" Overlay | 72.50 | |
| 500 | Tn | Machine Pave: Shim | 73.50 | |
| 1 | Ea | Mobilization | 1500.00 | |
| 22200 | LF | Gravel Shoulders | .75 | |
| | | | SUBTOTAL | |
| | | | SALES TAX | |
| | | | SHIPPING & HANDLING | |
| | | | OTHER | |
| | | | TOTAL | |

1. Please send two copies of your invoice.
2. Enter this order in accordance with the prices, terms, delivery method, and specifications listed above.
3. Please notify us immediately if you are unable to ship as specified.
4. Send all correspondence to:
John Hubbard
Town of North Hampton
233 Atlantic Avenue
Tel. 603.964.6442 Fax 603.964.1514

 Authorized by _____ Date 7/31/14

A-4

WHITE'S WELDING CO., INC.

6 KERSHAW AVENUE, HAMPTON, NEW HAMPSHIRE 03842 • TEL. 603/926-2261

SOLD TO

TOWN OF NO. HAMPTON, DPW
233 ATLANTIC AVE
NO. HAMPTON, NH 03862

PURCHASE ORDER

DATE

6-27-16

DEL DATE

ATTN JOHN HUBBARD

WHI-INVOICE

RE: PROVIDE SHOULDER ATTACHMENT

TOTAL COST \$5000⁰⁰

LABOR \$70⁰⁰ HR

INCLUDES STOCK MATERIALS

TOWN OF NO. HAMPTON TO SUPPLY
SPECIFIC PARTS

6/27/16 

A-6

Town of North Hampton

PURCHASE ORDER

237 Atlantic Avenue
North Hampton, NH 03862
Tel. 603.964.8087
Fax 603.964.1514

The following number must appear on all related correspondence,
shipping papers, and invoices: P.O. NUMBER: PW16008

To. **PC Help, Limited**
9850 S. Maryland Pkwy, Suite A-5183
Las Vegas, NV 89183

| P.O. DATE | REQUISITIONER | SHIP VIA | F.O.B. POINT | TERMS |
|-----------|---------------|----------|--------------|-------|
| 6/27/16 | Highway | | Office | |

| QTY | UNIT | DESCRIPTION | UNIT PRICE | TOTAL |
|-----|------|--|---------------------|-----------------|
| 1 | Ea | Tatems- Equipment maintenance software Gold package | 997.00 | 997.00 |
| | | | SUBTOTAL | 997.00 |
| | | | SALES TAX | |
| | | | SHIPPING & HANDLING | |
| | | | OTHER | |
| | | | TOTAL | \$997.00 |

- Please send two copies of your invoice.
- Enter this order in accordance with the prices, terms, delivery method, and specifications listed above.
- Please notify us immediately if you are unable to ship as specified.
- Send all correspondence to:
John Hubbard
Town of North Hampton
233 Atlantic Avenue
Tel. 603.964.6442 Fax 603.964.1514

 Authorized by _____ Date 6/27/16

Item # A-5, B-4&5

Highway/ Recycling Center Building Maintenance

6/24/2016

| Item | Units | | Unit Price | | Total |
|-----------------------------------|--------|----|---------------|---|----------|
| 1. Ross Bisplinghoff: Labor | 140.00 | Hr | 45.00 | = | 6300.00 |
| 2. Building Materials- Lumber, | 1.00 | Ea | 8000.00 | = | 8000.00 |
| 3. Lamprey Used Propane wall unit | 1.00 | Ea | 1000.00 | = | 1000.00 |
| Unit Installation | 1.00 | Ea | 2000.00 | = | 2000.00 |
| | | | Project Total | = | 17300.00 |

Licenses Pricing & Purchase Options

Scroll Down For Answers to Frequently Asked Questions

\$797 Total

Silver Package

- ✓ 1 TATEMS License
- ✓ 1 Year Version Upgrades
- ✓ 1 Year Unlimited Support
- ✓ \$50 Each Additional License (When Purchase at the Same Time)

1 TATEMS License \$797.00 USD ▼

Buy Now

\$997 Total

Gold Package

Popular

- ✓ 5 TATEMS Licenses
- ✓ 2 Years Version Upgrades
- ✓ 2 Years Unlimited Support
- ✓ \$50 Each Additional License (When Purchase at the Same Time)

5 TATEMS Licenses \$997.00 USD ▼

Buy Now

Questions? Here are the answers to some commonly asked

B-1

Town of North Hampton

233 Atlantic Avenue
North Hampton, NH 03862
Tel. 603.964.8087
Fax 603.964.1514

PURCHASE ORDER

The following number must appear on all related correspondence,
shipping papers, and invoices: C.O. NUMBER: 1

To. CCI Building Restoration & Waterproofing
14 Lafayette Road
North Hampton, NH 03862

| P.O. DATE | REQUISITIONER | SHIP VIA | F.O.B. POINT | TERMS |
|-----------|-----------------|----------|--------------|-------|
| 8/11/15 | Building Maint. | | Library | |

| QTY | UNIT | DESCRIPTION | UNIT PRICE | TOTAL |
|-----|------|---|---------------------|--------------------|
| 1 | Ea | Change Order #1 to contract dated May 5, 2015 Library Attic Fan/ Ventilation | 2,800.00 | 2,800.00 |
| | | | SUBTOTAL | 2,800.00 |
| | | | SALES TAX | |
| | | | SHIPPING & HANDLING | |
| | | | OTHER | |
| | | | TOTAL | \$ 2,800.00 |

- Please send two copies of your invoice.
- Enter this order in accordance with the prices, terms, delivery method, and specifications listed above.
- Please notify us immediately if you are unable to ship as specified.
- Send all correspondence to:
John Hubbard
Town of North Hampton
233 Atlantic Avenue
Tel. 603.964.6442 Fax 603.964.1514

 Authorized by _____ Date 8/11/15

Licenses Pricing & Purchase Options

Scroll Down For Answers to Frequently Asked Questions

\$797 Total

Silver Package

- ✓ 1 TATEMS License
- ✓ 1 Year Version Upgrades
- ✓ 1 Year Unlimited Support
- ✓ \$50 Each Additional License (When Purchase at the Same Time)

1 TATEMS License \$797.00 USD ▼

Buy Now

\$997 Total

Gold Package

Popular

- ✓ 5 TATEMS Licenses
- ✓ 2 Years Version Upgrades
- ✓ 2 Years Unlimited Support
- ✓ \$50 Each Additional License (When Purchase at the Same Time)

5 TATEMS Licenses \$997.00 USD ▼

Buy Now

Questions? Here are the answers to some commonly asked

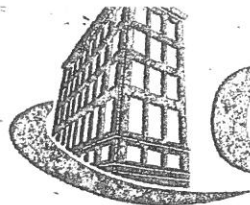

CCI BUILDING RESTORATION & WATERPROOFING

August 7, 2015

Mr. John Hubbard
Town of North Hampton
10 Airport Road
North Hampton, NH 03862

Sent via email: jhubbard@northhampton-nh.org

RE: 237A Atlantic Ave. – North Hampton Public Library Attic Fan Installation
North Hampton, NH

Dear Mr. Hubbard:

CCI, Inc. is pleased to submit the following scope and pricing information for work on the above referenced project. Please review this scope of work to ensure it meets your needs.

Scope

CCI to provide labor, equipment and materials to perform the following scope of work:

1. Install a 6" 305 CFM in-line thermostatically-controlled fan in the attic - Fan will have a backflow damper to avoid back-drafts
2. Install a 6" thru-roof vent
3. Connect the fan to the vent
4. Install two (2) thru-roof fresh air intakes

Excludes

- Winter Conditions
- Bonds
- Water & Power
- Engineering

Contract Price:

\$2,800

Payment Terms

Due in full upon completion. Any late payments over 30 days will be assessed at 2% per month overdue. Any legal fees associated with collecting overdue payments due will be at the expense of the owner.

Terms And Conditions

1. CCI, Inc. will provide certificate of insurance, upon request.
2. All work to be performed by an open shop labor force and in accordance with industry standards.
3. Price can be withdrawn at any time.
4. All work will be performed during regular work hours *unless otherwise noted*.
5. Where applicable the owner will receive and store (or permit the contractor to store) near the site, and properly protect from damage or loss, the materials and equipment for carrying out this contract, and allow the contractor reasonable use of light, heat, water, power and available elevators, hoists etc. necessary to perform this contract as well as access to roof, if required.
6. CCI, Inc. will provide submittals and a Work Schedule prior to commencement of any work, if so required. Submittals and sample testing provided to owner are a representative sample. Finish products may vary slightly in color, texture, etc.
7. We cannot guaranty against future water infiltration unless 100% restoration is being performed.
8. CCI, Inc. and its agents will not be held responsible for existing or future conditions resulting from weather element penetration/infiltration of the building envelope, including but not limited to mold and mildew, expressed structure deterioration and building content damage, unless specifically delineated in the scope of work section of this proposal. There is no guaranty or warranty, implied or otherwise, against any damages due to existing or future weather element penetration.

Phone: (603) 964-5073

(800) 797-7676

Fax: (603) 964-2183

CONTRACT DEPARTMENT\IIII\Proposals-Bids-
TOWN OF NORTH HAMPTON, NH\NORTH HAMPTON
PUBLIC LIBRARY ATTIC FAN PROPOSAL - 8-7-15.doc

www.ccibuilding.com

14 Lafayette Road
P.O. Box 695
North Hampton, NH 03862

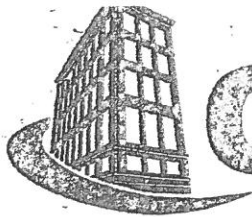

CCI BUILDING RESTORATION & WATERPROOFING

9. Any alteration or deviation from above specification involving extra costs will be executed only upon a written change order and will become an extra charge over and above the contract price.
10. All CCI, Inc. pricing is based on all existing materials being non-hazardous and does not include any special removal or disposal costs associated with such.
11. Proposal is contingent upon all materials and equipment necessary to complete the work are conventional and readily available.
12. CCI, Inc. shall not be responsible for damage or delay resulting from acts of God, civil commotion or disorders, labor strikes, picketing, fire, accidents, storms, delays or default by carriers or suppliers, inherent defects in subject premises, stoppage by the owner, owner's representatives or any other causes beyond reasonable control. If such a situation should occur, all work completed to date will be paid in full. Any expenses incurred due unnecessary delays within the control of the owner, will be the responsibility of the Owner or the Owners representative. If additional expenses are incurred on rental staging and equipment due to these delays, these charges will be the responsibility of the Owner or Owner's representative.
13. Any landscaping adjacent to our work area (including ivy, plantings, shrubs, trees, grass, curbing) will be protected whenever possible however we cannot replace any of these items if damage does occur, *unless otherwise noted.*
14. The customer shall furnish at no cost to the contractor, electricity, water and sanitary facilities.
15. Our proposal is based upon construction means and methods being completed according to industry standards. If the above subject property is on the Historical Registry (either locally or Federally) and if construction means and methods differ than stated above, the price may or may not have to be revised.
16. Warranty will not be provided until the contract has been paid in full.
17. Any Architectural and engineering services such as specifications and drawings beyond CCI's original proposal are not included. All fees associated with these items are excluded and not within our scope of work.

If you have any questions, please feel free to call me.

Sincerely,

Bill Sylvester
Vice President

I have read the above scope and terms. The above prices, specifications and conditions are satisfactory and are hereby accepted. You are authorized to proceed with the work as specified.

Owner/ Buyer Acceptance:
 By: [Signature]
 Print Name: John Hubbard
 Title: OPM Director
 Date: 8/11/15

Contractor:
 By: _____
 Print Name: Bill Sylvester
 Title: Vice President
 Date: _____

Proposal must be signed and faxed to (603)964-2183 before work will be scheduled.

Phone: (603) 964-5073
(800) 797-7676
Fax: (603) 964-2183

www.ccibuilding.com

14 Lafayette Road
P.O. Box 695
North Hampton, NH 03861

Item # B-3

North Hampton Library

Paving Estimate- Phase 1

6/24/2016

| Item | Units | | Unit Price | | Total |
|--|--------------|----|----------------------|----------|-----------------|
| 1. Excavate Pavement/ Grade Parking Area | 1.00 | LS | 6000.00 | = | 6000.00 |
| 2. HBP Machine Method | 300.00 | Tn | 72.50 | = | 21750.00 |
| 3. Hand Pave | 10.00 | Tn | 124.00 | = | 1240.00 |
| 4. Mobilization | 1.00 | Ea | 500.00 | = | 500.00 |
| | | | Project Total | = | 29490.00 |

Bourassa Construction, LLC, 145 Union Rd, Stratham, NH 03885
PROPOSAL

Paving Projects: 2014-2015

Date: July 29, 2014

To: Town of North Hampton
 Public Works Facility
 10 Airport Road
 North Hampton, NH 03862

| | Estimated Units | Unit Bid Price | Extended Bid Price |
|---|--------------------|-------------------|--|
| A. North Road (Post Rd to Rte 1) | | | |
| 1. Install bituminous concrete shim (NH 3/8" top) (tons) | 500 | \$ 73.50 | \$ 36,750.00 |
| 2. Install an average 1-1/2" top surface course (NH 1/2" Top) (tons) | 1,300 | \$ 72.50 | \$ 94,250.00 |
| 3. Bituminous concrete handwork; driveway approaches, trench patch (tons) | 60 | \$ 124.00 | \$ 7,440.00 |
| 4. Install an average of 2' crushed gravel shoulders to roadway (LF) | 12,000 | \$ 0.75 | \$ 9,000.00 |
| 5. Mobilization, cold plane transitions and construction signage for project. Lump Sum (unit) | 1 | \$ 500.00 | \$ 500.00 |
| | | | North Road Total \$ 147,940.00 |
| B. Willow Ave./Causeway Rd. | | | |
| 1. Reclaim approx. 1400 LF of existing pavement, rough grade surplus material on existing roadway, fine grade and compact | 5,800 | \$ 2.34 | \$ 13,572.00 |
| 2. Install a 2" bituminous concrete base course to roadway. (tons) | 670 | \$ 70.00 | \$ 46,900.00 |
| 3. Install a 1-1/2" top surface course to entire roadway (tons) | 560 | \$ 72.50 | \$ 40,600.00 |
| 4. Bituminous concrete handwork; driveway approaches (tons) | 20 | \$ 124.00 | \$ 2,480.00 |
| 5. Install an average of 2' crushed gravel shoulders to roadway (LF) | 4,600 | \$ 0.75 | \$ 3,450.00 |
| 6. Mobilization, project clean up, and construction signage for project. Lump Sum (unit) | 1 | \$ 500.00 | \$ 500.00 |
| | | | Willow Ave./Causeway Rd Total \$ 107,502.00 |
| C. River Road | | | |
| 1. Install an average 1-1/2" top surface course to roadway (tons) | 260 | \$ 72.50 | \$ 18,850.00 |
| 2. Install an average of 2' crushed gravel shoulders to roadways (LF) | 2,000 | \$ 0.75 | \$ 1,500.00 |
| 3. Bituminous concrete handwork; driveway approaches (tons) | 20 | \$ 124.00 | \$ 2,480.00 |
| | | | River Road Total \$ 22,830.00 |
| D. Old Locke Road | | | |
| 1. Install an average 1-1/2" top surface course to roadway (tons) | 450 | \$ 72.50 | \$ 32,625.00 |
| 2. Install an average of 2' crushed gravel shoulders to roadways (LF) | 3,600 | \$ 0.75 | \$ 2,700.00 |
| 3. Bituminous concrete handwork; driveway approaches (tons) | 50 | \$ 124.00 | \$ 6,200.00 |
| 4. Mobilization, cold plane transitions, and construction signage for project. Lump Sum (unit) | 1 | \$ 500.00 | \$ 500.00 |
| | | | Old Locke Road Total \$ 42,025.00 |
| | | | Project Grand Total \$ 320,297.00 |

Notes:
 A. Crushed gravel or loam required for shoulders will be furnished by the Town of North Hampton
 B. Apply bituminous tack coat prior to overlays

ACCEPTANCE OF PROPOSAL

TOWN OF NORTH HAMPTON

Signature: 
 Title: Town Administrator, duly authorized
 ON July 28, 2014
 Date: July 31, 2014

BOURASSA CONSTRUCTION, LLC

Signature: 
 Name/Title: Gary Bourassa - Owner
 Date: 7/29/2014

Town of North Hampton

233 Atlantic Avenue
 North Hampton, NH 03862
 Tel. 603.964.8087
 Fax 603.964.1514

PURCHASE ORDER

The following number must appear on all related correspondence,
 shipping papers, and invoices: P.O. NUMBER: PW14038

To. **Bourassa Construction LLC**
 145 Union Road

Stratham, NH 03885

| P.O. DATE | REQUISITIONER | SHIP VIA | F.O.B. POINT | TERMS |
|-----------|---------------|----------|--------------|-------|
| 7/31/14 | | | 14-15 Paving | |

| QTY | UNIT | DESCRIPTION | UNIT PRICE | TOTAL |
|---------------------|------|------------------------------|------------|-------|
| 5800 | SY | Reclaim/Grade | 2.34 | |
| 670 | Tn | Machine pave 2" base | 70.00 | |
| 150 | Tn | Handpave | 124.00 | |
| 2570 | Tn | Machine Pave: 1 1/2" Overlay | 72.50 | |
| 500 | Tn | Machine Pave: Shim | 73.50 | |
| 1 | Ea | Mobilization | 1500.00 | |
| 22200 | LF | Gravel Shoulders | .75 | |
| SUBTOTAL | | | | |
| SALES TAX | | | | |
| SHIPPING & HANDLING | | | | |
| OTHER | | | | |
| TOTAL | | | | |

- Please send two copies of your invoice.
- Enter this order in accordance with the prices, terms, delivery method, and specifications listed above.
- Please notify us immediately if you are unable to ship as specified.
- Send all correspondence to:
 John Hubbard
 Town of North Hampton
 233 Atlantic Avenue
 Tel. 603.964.6442 Fax 603.964.1514

 Authorized by _____ Date 7/31/14

C-1



Estimate

BILL TO:

Town of North Hampton
North Hampton, NH 03862

Issue Date:
04/17/16

Expiration Date:
05/17/16

Strip and reroof storage shed located at Center Cemetery

| | |
|--|------------------|
| Estimated Labor: 12 hrs @ \$45/hr | \$540.00 |
| Estimated Helper Labor: 12 hrs @ \$30/hr | \$360.00 |
| Estimated Mat'l's: | \$800.00 |
| Estimated Disposal Fee: | \$125.00 |
| Estimate Total | \$1825.00 |

This is an estimate only, not a contract. This estimate is for completing the job described above, based on our evaluation. It does not include unforeseen price increases or additional labor and materials which may be required should problems arise.

Thank you for your business!

Chevalier Carpentry 45 Main St, Fremont, NH 03044 Phone 603-479-8209 E-mail: chevaliercarpentry@comcast.net

Approved:

Date: 4/24/16

Town of North Hampton

233 Atlantic Avenue
 North Hampton, NH 03862
 Tel. 603.964.8087
 Fax 603.964.1514

PURCHASE ORDER

The following number must appear on all related correspondence, shipping papers, and invoices: P.O. NUMBER: PW14038

To. Bourassa Construction LLC
 145 Union Road

Stratham, NH 03885

| P.O. DATE | REQUISITIONER | SHIP VIA | F.O.B. POINT | TERMS |
|-----------|---------------|----------|--------------|-------|
| 7/31/14 | | | 14-15 Paving | |

| QTY | UNIT | DESCRIPTION | UNIT PRICE | TOTAL |
|---------------------|------|------------------------------|------------|-------|
| 5800 | SY | Reclaim/Grade | | |
| 670 | Tn | Machine pave 2" base | 2.34 | |
| 150 | Tn | Handpave | 70.00 | |
| 2570 | Tn | Machine Pave: 1 1/2" Overlay | 124.00 | |
| 500 | Tn | Machine Pave: Shim | 72.50 | |
| 1 | Ea | Mobilization | 73.50 | |
| 22200 | LF | Gravel Shoulders | 1500.00 | |
| | | | .75 | |
| SUBTOTAL | | | | |
| SALES TAX | | | | |
| SHIPPING & HANDLING | | | | |
| OTHER | | | | |
| TOTAL | | | | |

- Please send two copies of your invoice.
- Enter this order in accordance with the prices, terms, delivery method, and specifications listed above.
- Please notify us immediately if you are unable to ship as specified
- Send all correspondence to:
 John Hubbard
 Town of North Hampton
 233 Atlantic Avenue
 Tel. 603.964.6442 Fax 603.964.1514

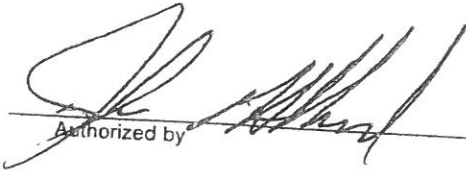
 Authorized by _____ Date 7/31/14

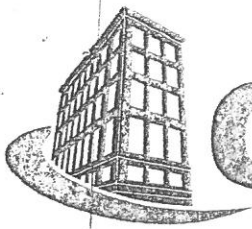

CCI BUILDING RESTORATION & WATERPROOFING

June 10, 2016

Mr. John Hubbard
Town of North Hampton, NH
10 Airport Road
North Hampton, NH 03862

Sent via email: jhubbard@northhampton-nh.gov

RE: Center Cemetery, Post Road – Shed roof replacement
North Hampton, NH

Dear Mr. Hubbard:

CCI, Inc. is pleased to submit the following scope and pricing information for work on the above referenced project. Please review this scope of work to ensure it meets your needs.

Scope

CCI to provide labor, equipment and materials to perform the following scope of work

Work area – Center Cemetery shed (approximately 22' X 16' with 8" overhangs):

1. Remove and properly dispose of the existing roof materials on the shed
2. Install new ice and water shield, new 25-30 year arch shingles and drip edge

Excludes

•Winter Conditions •Bonds •Water & Power •Engineering

Contract Price:

\$2,200

Payment Terms

Provide a 25% deposit prior to the start of work. Payment balance is due as work progresses based on percent complete. Any late payments over 30 days will be assessed at 2% per month overdue. Any legal fees associated with collecting overdue payments due will be at the expense of the owner.

Terms And Conditions

1. CCI, Inc. will provide certificate of insurance, upon request.
2. All work to be performed by an open shop labor force and in accordance with industry standards.
3. Price can be withdrawn at any time.
4. All work will be performed during regular work hours *unless otherwise noted*.
5. Where applicable the owner will receive and store (or permit the contractor to store) near the site, and properly protect from damage or loss, the materials and equipment for carrying out this contract, and allow the contractor reasonable use of light, heat, water, power and available elevators, hoists etc. necessary to perform this contract as well as access to roof, if required.
6. CCI, Inc. will provide submittals and a Work Schedule prior to commencement of any work, if so required. Submittals and sample testing provided to owner are a representative sample. Finish products may vary slightly in color, texture, etc.
7. We cannot guaranty against future water infiltration unless 100% restoration is being performed.
8. CCI, Inc. and its agents will not be held responsible for existing or future conditions resulting from weather element penetration/infiltration of the building envelope, including but not limited to mold and mildew, expressed structure deterioration and building content damage, unless specifically delineated in the scope of work section of this proposal. There is no guaranty or warranty, implied or otherwise, against any damages due to existing or future weather element penetration.
9. Any alteration or deviation from above specification involving extra costs will be executed only upon a written change order and will become an extra charge over and above the contract price.

Phone: (603) 964-5073

(800) 797-7676

Fax: (603) 964-2183

www.ccibuilding.com

14 Lafayette Road
P.O. Box 695
North Hampton, NH 03862

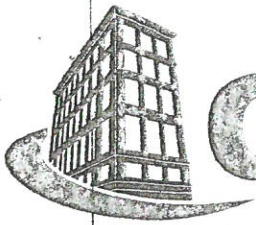

CCI BUILDING RESTORATION & WATERPROOFING

10. All CCI, Inc. pricing is based on all existing materials being non-hazardous and does not include any special removal or disposal costs associated with such.
11. Proposal is contingent upon all materials and equipment necessary to complete the work are conventional and readily available.
12. CCI, Inc. shall not be responsible for damage or delay resulting from acts of God, civil commotion or disorders, labor strikes, picketing, fire, accidents, storms, delays or default by carriers or suppliers, inherent defects in subject premises, stoppage by the owner, owner's representatives or any other causes beyond reasonable control. If such a situation should occur, all work completed to date will be paid in full. Any expenses incurred due unnecessary delays within the control of the owner, will be the responsibility of the Owner or the Owners representative. If additional expenses are incurred on rental staging and equipment due to these delays, these charges will be the responsibility of the Owner or Owner's representative.
13. Any landscaping adjacent to our work area (including ivy, plantings, shrubs, trees, grass, curbing) will be protected whenever possible however we cannot replace any of these items if damage does occur, *unless otherwise noted.*
14. The customer shall furnish at no cost to the contractor, electricity, water and sanitary facilities.
15. Our proposal is based upon construction means and methods being completed according to industry standards. If the above subject property is on the Historical Registry (either locally or Federally) and if construction means and methods differ than stated above, the price may or may not have to be revised.
16. Warranty will not be provided until the contract has been paid in full.
17. Any Architectural and engineering services such as specifications and drawings beyond CCI's original proposal are not included. All fees associated with these items are excluded and not within our scope of work.

If you have any questions, please feel free to call me.

Sincerely,

Bill Sylvester
Vice President

I have read the above scope and terms. The above prices, specifications and conditions are satisfactory and are hereby accepted. You are authorized to proceed with the work as specified.

Owner/ Buyer Acceptance:

Contractor:

By: _____

By: _____

Print Name: _____

Print Name: Bill Sylvester

Title: _____

Title: Vice President

Date: _____

Date: _____

Proposal must be signed and faxed to (603)964-2183 before work will be scheduled.

Phone: (603) 964-5073
(800) 797-7676
Fax: (603) 964-2183

www.ccibuilding.com

14 Lafayette Road
P.O. Box 69
North Hampton, NH 0386



ROBERT W. GRAY
CONSTRUCTION LLC

"Third and Fourth Generation Builders"



June 10, 2016

Town of North Hampton
Post Road Cemetery
North Hampton, New Hampshire

RE: Roof Replacement – Proposal
Town of North Hampton, New Hampshire

1. **Demolition (Removal and Disposal):**
 - a. Existing roof at the building down to the sheathing.
 - b. All debris generated from the new construction.
2. **New roof specifications:**
 - a. 8" white aluminum drip edge at the roof eave and rake trim.
 - b. Grace Ice and Water Shield at entire roof.
 - c. Supply and install asphalt roof shingles (30 year architectural style – Certainteed Landmark or equal).
 - d. Flash in chimney to new roofing.
3. **Other:**
 - a. Includes all labor, materials and building permit.
 - b. Clean and protect the existing house exterior during construction.
 - c. Site dumpster provided by Gray Construction.

Total Price: \$ 2,600.00

Not included in the price:

1. Asbestos/lead paint removal, if necessary.
2. Any hidden rot repair to sheathing will be additional cost if uncovered.

Thank you for the chance to bid,

Robert W. Gray
Robert W. Gray Construction, LLC



ROBERT W. GRAY
CONSTRUCTION LLC

"Third and Fourth Generation Builders"



** Gray Construction carries the required insurance coverage (Liability and Workers Comp) for the company employees and subcontractors for the State of New Hampshire.

** If you have any questions, we can be reached at:

Phone: (603) 964-9234

Fax: (603) 964-9223

E-mail: bob@graycontractors.com

** Proposal price good for 90 days from date of proposal.

Item # C-2

Center Cemetery

Paving Estimate- Phase 1

6/24/2016

| Item | Units | Unit Price | Total |
|---|-----------|-----------------|---------|
| 1. HBP Machine/ Hand Method Combination | 82.00 Ton | 93.50 = | 7667.00 |
| 2. Mobilization | 1.00 Ea | 500.00 = | 500.00 |
| | | Project Total = | 8167.00 |

Bourassa Construction, LLC, 145 Union Rd, Stratham, NH 03885

PROPOSAL

Paving Projects: 2014-2015

Date: July 29, 2014

To: Town of North Hampton
Public Works Facility
10 Airport Road
North Hampton, NH 03862

| | | | | | |
|----|--|--------|----|-------------------------|----------------------|
| A. | North Road (Post Rd to Rte 1) | | | | |
| 1. | Install bituminous concrete shim (NH 3/8" top) (tons) | 500 | \$ | 73.50 | \$ 36,750.00 |
| 2. | Install an average 1-1/2" top surface course (NH 1/2" Top) (tons) | 1,300 | \$ | 72.50 | \$ 94,250.00 |
| 3. | Bituminous concrete handwork; driveway approaches, trench patch (tons) | 60 | \$ | 124.00 | \$ 7,440.00 |
| 4. | Install an average of 2' crushed gravel shoulders to roadway (LF) | 12,000 | \$ | 0.75 | \$ 9,000.00 |
| 5. | Mobilization, cold plane transitions and construction signage for project. Lump Sum (unit) | 1 | \$ | 500.00 | \$ 500.00 |
| | | | | North Road Total | \$ 147,940.00 |

| | | | | | |
|----|--|-------|----|--------------------------------------|----------------------|
| B. | Willow Ave./Causeway Rd. | | | | |
| 1. | Reclaim approx. 1400 LF of existing pavement, rough grade surplus material on existing roadway, fine grade and compact | 5,800 | \$ | 2.34 | \$ 13,572.00 |
| 2. | Install a 2" bituminous concrete base course to roadway. (tons) | 670 | \$ | 70.00 | \$ 46,900.00 |
| 3. | Install a 1-1/2" top surface course to entire roadway (tons) | 560 | \$ | 72.50 | \$ 40,600.00 |
| 4. | Bituminous concrete handwork; driveway approaches (tons) | 20 | \$ | 124.00 | \$ 2,480.00 |
| 5. | Install an average of 2' crushed gravel shoulders to roadway (LF) | 4,600 | \$ | 0.75 | \$ 3,450.00 |
| 6. | Mobilization, project clean up, and construction signage for project. Lump Sum (unit) | 1 | \$ | 500.00 | \$ 500.00 |
| | | | | Willow Ave./Causeway Rd Total | \$ 107,502.00 |

| | | | | | |
|----|--|-------|----|-------------------------|---------------------|
| C. | River Road | | | | |
| 1. | Install an average 1-1/2" top surface course to roadway (tons) | 260 | \$ | 72.50 | \$ 18,850.00 |
| 2. | Install an average of 2' crushed gravel shoulders to roadways (LF) | 2,000 | \$ | 0.75 | \$ 1,500.00 |
| 3. | Bituminous concrete handwork; driveway approaches (tons) | 20 | \$ | 124.00 | \$ 2,480.00 |
| | | | | River Road Total | \$ 22,830.00 |

| | | | | | |
|----|---|-------|----|-----------------------------|---------------------|
| D. | Old Locke Road | | | | |
| 1. | Install an average 1-1/2" top surface course to roadway (tons) | 450 | \$ | 72.50 | \$ 32,625.00 |
| 2. | Install an average of 2' crushed gravel shoulders to roadways (LF) | 3,600 | \$ | 0.75 | \$ 2,700.00 |
| 3. | Bituminous concrete handwork; driveway approaches (tons) | 50 | \$ | 124.00 | \$ 6,200.00 |
| 4. | Mobilization, cold plane transitions, and construction signage for project. Lump Sum (unit) | 1 | \$ | 500.00 | \$ 500.00 |
| | | | | Old Locke Road Total | \$ 42,025.00 |

Project Grand Total \$ 320,297.00

Notes:
A. Crushed gravel or loam required for shoulders will be furnished by the Town of North Hampton
B. Apply bituminous tack coat prior to overlays

ACCEPTANCE OF PROPOSAL

TOWN OF NORTH HAMPTON

BOURASSA CONSTRUCTION, LLC

Signature: 
Title: Town Administrator, duly authorized
on July 28, 2014
Date: July 31, 2014

Signature: 
Name/Title: Gary Bourassa - Owner
Date: 7/29/2014

Jim Maggiore, Chair
Larry Miller, Vice Chair
Rick Stanton, Member



Municipal Offices
233 Atlantic Avenue
North Hampton, NH 03862

Tel: (603) 964-8087
Fax: (603) 964-1514

TOWN OF NORTH HAMPTON, NEW HAMPSHIRE
THE SELECT BOARD

MOTIONS IN RE POLICE DEPARTMENT PURCHASES

PURCHASED
IN JUNE ✓

1. I move to encumber the sum of \$11,096.25 from the FY 2016 Operating Budget for the purpose of purchasing tasers pursuant to a contract with Taser International dated June 15, 2016.

PURCHASED
IN JUNE ✓

2. I move to encumber the sum of \$3,502.82 from the FY 2016 Operating Budget for the purpose of purchasing Streamlight TLR-1 HL Weapon Lights and Aimpoint Red Dot Rifle Sites pursuant to a contract with Galls, of Lexington, Kentucky dated June 23, 2016.

✓

3. I move to encumber the sum of \$248.98 from the FY 2016 Operating Budget for the purpose of purchasing a Blackhawk Dynamic Entry CQB Ram pursuant to a contract with Tacticalgear.com dated June 10, 2016.

✓

4. I move to encumber the sum of \$2,196.66 from the FY 2016 Operating Budget for the purpose of purchasing ammunition pursuant to a contract with Eagle Point Gun, of Thorofare, New Jersey dated June 23, 2016.

PURCHASED
IN JUNE ✓

5. I move to encumber the sum of \$6,839.54 from the FY 2016 Operating Budget for the purpose of purchasing two (2) Motorola APX6500Li mobile cruiser radios pursuant to a contract with 2-Way Communications, of Newington, New Hampshire dated June 21, 2016.

PURCHASED
IN JUNE ✓

6. I move to encumber the sum of \$14,200 from the FY 2016 Operating Budget for the purpose of purchasing five (5) Driver Feedback Signs (solar powered) pursuant to a contract with Traffic Logix, Inc. of Spring Valley, New York dated June 23, 2016.

PURCHASED
IN JUNE ✓

7. I move to encumber the sum of \$13,098.00 from the FY 2016 Operating Budget for the purpose of purchasing two (2) Radar Trailers (solar powered) pursuant to a contract with Traffic Logix, Inc. of Spring Valley, New York dated June 23, 2016.

Jim Maggiore

RH Stanton

Larry Miller 6-27-16

\$ 51,182.25 TOTAL

(48,736.61) F116

\$ 2,445.64 ENCUMBERED

North Hampton Police Department



2015/2016 Budget Surplus Request

TOWN OF NORTH HAMPTON
233 ATLANTIC AVENUE
NORTH HAMPTON, NH 03862

MICHAEL E. MADDOCKS
CHIEF



POLICE DEPARTMENT

TELEPHONE
BUSINESS (603) 964-8621
EMERGENCY (603) 679-2225
.....9-1-1
FAX NO. (603) 964-8831

Index

- 1) Tasers - \$11,096.25
 - 2) Weapon Lights - \$3,502.82
 - Streamlight TLR-1 HL Weapon Lights
 - Aimpoint Red Dot Rifle Sights
 - 3) Blackhawk Dynamic Entry CQB Ram - \$248.98
 - 4) Ammunition - \$2,191.66
 - 5) Cruiser Radios - \$6,839.54
 - 6) Driver Feedback Signs - \$14,200.00
 - 7) Radar Trailers - \$13,098.00
- Total Requested - \$51,177.25

TOWN OF NORTH HAMPTON
233 ATLANTIC AVENUE
NORTH HAMPTON, NH 03862



POLICE DEPARTMENT

MICHAEL E. MADDOCKS
CHIEF

TELEPHONE
BUSINESS (603) 964-8
EMERGENCY (603) 679-2220
.....9-1-1
FAX NO. (603) 964-8831

To: Mr. Paul Apple
From: Chief Michael E. Maddocks
Subject: Expenditure of Funds
Date: June 23, 2016

Please accept this request to be on the selectboard agenda in order to expend budget surplus for the purchase of ten (10) Tasers, Model X26P and holsters in the amount of \$11,096.25 with shipping.

This will allow Taser units to be distributed to each officer. The current stock of Tasers are failing due to the age of the units.

Respectfully,

A handwritten signature in black ink, appearing to read "Michael E. Maddocks", is written over a horizontal line.

Michael E. Maddocks

TASER International

Protect Life. Protect Truth.

17800 N 85th St.
 Scottsdale, Arizona 85255
 United States
 Phone: (800) 978-2737
 Fax: 888-843-4309

Mike Maddocks
 (603) 964-2198
 mmaddocks@northhampton-nh.gov



TASER

Quotation

Quote: Q-65857-2
 Date: 6/9/2016 11:50 AM
 Quote Expiration: 6/30/2016
 Contract Start Date*: 6/15/2016
 Contract Term: 5 years

AX Account Number:
 151809

Bill To:
 North Hampton Police Department - NH
 233 ATLANTIC AVE.
 North Hampton, NH 03862
 US

Ship To:
 Mike Maddocks
 North Hampton Police Department - NH
 233 ATLANTIC AVE.
 North Hampton, NH 03862
 US

| SALESPERSON | PHONE | EMAIL | DELIVERY METHOD | PAYMENT METHOD |
|-------------|--------------|-----------------|-----------------|----------------|
| Colin Fine | 480-463-2167 | cfine@taser.com | Fedex - Ground | Net 30 |

*Note this will vary based on the shipment date of the product.

Hardware & TAP Year 1 Due Net 30

| QTY | ITEM # | DESCRIPTION | UNIT PRICE | TOTAL BEFORE DISCOUNT | DISCOUNT (\$) | NET TOTAL |
|---|--------|---|------------|-----------------------|---------------|---------------|
| 10 | 11003 | HANDLE, YELLOW, CLASS III, X26P | USD 931.45 | USD 9,314.50 | USD 0.00 | USD 9,314.50 |
| 10 | 85058 | TASER ASSURANCE PLAN CEW, X26P | USD 0.00 | USD 0.00 | USD 0.00 | USD 0.00 |
| 10 | 85059 | TASER ASSURANCE PLAN CEW ANNUAL PAYMENT, X26P | USD 197.22 | USD 1,972.20 | USD 1,500.00 | USD 472.20 |
| 10 | 11501 | HOLSTER, BLACKHAWK, RIGHT, X26P | USD 55.11 | USD 551.10 | USD 0.00 | USD 551.10 |
| 10 | 11010 | XPPM, BATTERY PACK, X26P | USD 65.72 | USD 657.20 | USD 0.00 | USD 657.20 |
| 1 | 22013 | KIT, DATAPORT DOWNLOAD, USB, X2/ X26P | USD 170.52 | USD 170.52 | USD 170.52 | USD 0.00 |
| Hardware & TAP Year 1 Due Net 30 Total Before Discounts: | | | | | | USD 12,665.52 |
| Hardware & TAP Year 1 Due Net 30 Discount: | | | | | | USD 1,670.52 |
| Hardware & TAP Year 1 Due Net 30 Net Amount Due: | | | | | | USD 10,995.00 |

w/shipping

\$ 11,096.25

TAP Year 2 Due 2017

| QTY | ITEM # | DESCRIPTION | UNIT PRICE | TOTAL BEFORE DISCOUNT | DISCOUNT (\$) | NET TOTAL |
|--|--------|---|------------|-----------------------|---------------|--------------|
| 10 | 85059 | TASER ASSURANCE PLAN CEW ANNUAL PAYMENT, X26P | USD 197.22 | USD 1,972.20 | USD 0.00 | USD 1,972.20 |
| TAP Year 2 Due 2017 Total Before Discounts: | | | | | | USD 1,972.20 |
| TAP Year 2 Due 2017 Net Amount Due: | | | | | | USD 1,972.20 |

TAP Year 3 Due 2018

| QTY | ITEM # | DESCRIPTION | UNIT PRICE | TOTAL BEFORE DISCOUNT | DISCOUNT (\$) | NET TOTAL |
|--|--------|---|------------|-----------------------|---------------|--------------|
| 10 | 85059 | TASER ASSURANCE PLAN CEW ANNUAL PAYMENT, X26P | USD 197.22 | USD 1,972.20 | USD 0.00 | USD 1,972.20 |
| TAP Year 3 Due 2018 Total Before Discounts: | | | | | | USD 1,972.20 |
| TAP Year 3 Due 2018 Net Amount Due: | | | | | | USD 1,972.20 |

TAP Year 4 Due 2019

| QTY | ITEM # | DESCRIPTION | UNIT PRICE | TOTAL BEFORE DISCOUNT | DISCOUNT (\$) | NET TOTAL |
|--|--------|---|------------|-----------------------|---------------|--------------|
| 10 | 85059 | TASER ASSURANCE PLAN CEW ANNUAL PAYMENT, X26P | USD 197.22 | USD 1,972.20 | USD 0.00 | USD 1,972.20 |
| TAP Year 4 Due 2019 Total Before Discounts: | | | | | | USD 1,972.20 |
| TAP Year 4 Due 2019 Net Amount Due: | | | | | | USD 1,972.20 |

TAP Year 5 Due 2020

| QTY | ITEM # | DESCRIPTION | UNIT PRICE | TOTAL BEFORE DISCOUNT | DISCOUNT (\$) | NET TOTAL |
|--|--------|---|------------|-----------------------|---------------|--------------|
| 10 | 85059 | TASER ASSURANCE PLAN CEW ANNUAL PAYMENT, X26P | USD 197.22 | USD 1,972.20 | USD 0.00 | USD 1,972.20 |
| TAP Year 5 Due 2020 Total Before Discounts: | | | | | | USD 1,972.20 |
| TAP Year 5 Due 2020 Net Amount Due: | | | | | | USD 1,972.20 |

| | |
|---|---------------|
| Subtotal | USD 18,883.80 |
| Estimated Shipping & Handling Cost | USD 101.25 |
| Grand Total | USD 18,985.05 |

**TASER International, Inc.'s Sales Terms and Conditions
for Direct Sales to End User Purchasers**

By signing this Quote, you are entering into a contract and you certify that you have read and agree to the provisions set forth in this Quote and TASER's Master Services and Purchasing Agreement posted at www.taser.com/legal. You represent that you are lawfully able to enter into contracts and if you are entering into this agreement for an entity, such as the company, municipality, or government agency you work for, you represent to TASER that you have legal authority to bind that entity. If you do not have this authority, do not sign this Quote.

Signature:

Date:

Name (Print):

Title:

PO# (if needed):

Quote: Q-65857-2

Please sign and email to Colin Fine at cfine@taser.com or fax to 888-843-4309

THANK YOU FOR YOUR BUSINESS!

'Protect Life' and © are trademarks of TASER International, Inc., and TASER® is a registered trademark of TASER International, Inc., registered in the U.S.
© 2013 TASER International, Inc. All rights reserved.

TOWN OF NORTH HAMPTON
233 ATLANTIC AVENUE
NORTH HAMPTON, NH 03862



POLICE DEPARTMENT

MICHAEL E. MADDOCKS
CHIEF

TELEPHONE
BUSINESS (603) 964-8
EMERGENCY (603) 679-22
.....9-1-1
FAX NO. (603) 964-8831

To: Mr. Paul Apple
From: Chief Michael E. Maddocks
Subject: Expenditure of Funds
Date: June 23, 2016

Please accept this request to be on the selectboard agenda in order to expend budget surplus for the purchase of Weapon Lights in the amount of \$3,502.82 with shipping. The department looks to purchase thirteen (13) Streamlight TLR-1 HL Weapon Lights (\$1,767.87) and two (2) Aimpoint Red Dot Rifle Sights (\$1,726.00).

The purchase of the Streamlight weapon lights would replace the aging weapon lights currently issued to North Hampton police officers purchased in 2009. The purchase of the Aimpoint rifle sights will increase the accuracy of officers with the patrol rifle.

Originally the department sought \$3,562.66 for the weapon lights, however we were able to find a different supplier for \$3,502.82

Respectfully,

Michael E. Maddocks

Steven Janvrin

From: orderconfirm@galls.com on behalf of Galls <orderconfirm@galls.com>
Sent: Thursday, June 23, 2016 11:01 AM
To: Steven Janvrin
Subject: Galls Order Confirmation

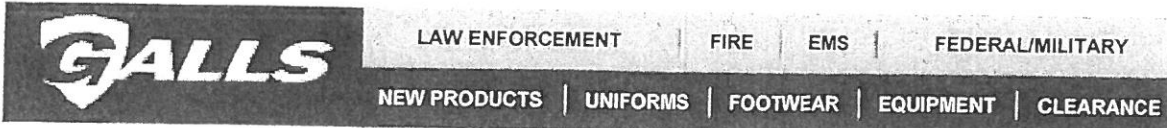

Hi NORTH HAMPTON POLICE DEPT,

ORDER INFORMATION

Thank you for shopping at Galls. This is a summary of your order.

Order Number: 6253056

Order Date: 06/23/2016

Payments:

On Account

Ship To:

NORTH HAMPTON POLICE DEPT
233 ATLANTIC AVE
NORTH HAMPTON, NH 03862

Customer PO#: STEVEN JANVRIN

Order Summary

| Item No. | Description | Ordered | Item Price | Total Price |
|-----------|--|---------|------------|-------------|
| SA571 | Aimpoint M4s 2 MOA Red Dot Temporarily out of stock - a little more time is needed to provide an estimated ship date | 2 | 863.00 | 1,726.00 |
| FH308 BLK | Streamlight TLR 1 HL Tactical Gun Mount Weapon Light COLOR: BLACK | 13 | 135.99 | 1,767.87 |

Merchandise Total: 3,493.87
Shipping: 8.95
Sales Tax:
Order Total: 3,502.82

Your order may ship in various intervals. If an item is on backorder or ships directly from our suppliers your credit card is not charged until the item ships. Your credit card statement will show this purchase from GALLS. If items have shipped from our suppliers, we may not be able to process cancellation requests.

Order Status

You can check your order status anytime by signing in to your Galls account or by clicking [here](#). If you have any questions or concerns, [email us](#) or call us toll-free at 866.673.7643.

Recommendations Just for You

Below are some popular products for you based on your past selections. If you need help completing another purchase, let us know. Call, [click](#) or [visit us](#).

Galls, LLC. - 1340 Russell Cave Road Lexington, KY 40505 | 866.673.7643
Galls respects your privacy, please review our [privacy policy](#).
© 2015 Galls, LLC.

Galls is your reliable source for quality, in-stock public safety equipment and apparel. Like you, we're quick, efficient, and effective. We understand that the demanding needs of your profession drive your purchasing decisions, so we demand the quality gear you require to do your job.

Each year, over one million men and women trust us to supply their essential gear and supplies. With over 45 years in the industry, it's easy to see why. Simply put, we are
The Authority in Public Safety

With our award-winning catalog, convenient online ordering, dedicated sales reps, retail and service centers, we're always here right when you need us.

Wherever your tough profession takes you, you'll find we have what you need to get through in one piece. With so many people counting on you to meet the demands of your job and your duty, Galls stands ready to help you meet the challenge.

TOWN OF NORTH HAMPTON
233 ATLANTIC AVENUE
NORTH HAMPTON, NH 03862



MICHAEL E. MADDOCKS
CHIEF

TELEPHONE
BUSINESS ----- (603) 964-8621
EMERGENCY ----- (603) 679-2225
-----9-1-1
FAX NO. ----- (603) 964-8831

POLICE DEPARTMENT

To: Mr. Paul Apple
From: Chief Michael E. Maddocks
Subject: Expenditure of Funds
Date: June 23, 2016

Please accept this request to be on the selectboard agenda in order to expend budget surplus for the purchase of a Blackhawk Dynamic Entry CQB Ram in the amount of \$248.98 with shipping. The purchase of dynamic ram would be used to make quick entry into a residence for emergency purposes.

Respectfully,

A handwritten signature in black ink, appearing to read "Michael E. Maddocks", is written over a horizontal line.

Michael E. Maddocks

Blackhawk Dynamic Entry CQB Ram
Item #: DE-CQB
\$245.99



Blackhawk Dynamic Entry CQB Ram
Item #: DE-CQB
\$245.99

Color: Black

W/ Shipping \$248.98

Color: Black

Size: Dynamic Entry CQB Ram

Quantity: 1

ADD TO CART

Order Multiple Sizes/Colors: **[BULK ORDER TOOL \(HTTP://TACTICALGEAR.COM/MULTI-ADD-TO-CART?PGID=3834\)](http://tacticalgear.com/multi-add-to-cart?pgid=3834)**



Please Note: This item is on backorder with the manufacturer and will ship the instant it becomes available. Please [contact us \(http://tacticalgear.com/contact-us\)](http://tacticalgear.com/contact-us) with any questions.

Important: Please allow up to an additional 2-3 days processing time on this item.

DESCRIPTION

AVAILABILITY



Blackhawk Dynamic Entry CQB Ram

Safely and efficiently breach doors with the Blackhawk Dynamic Entry CQB Ram. This 23-pound ram is able to take down lightweight exterior and most interior doors. It's more than resilient and powerful. This ram also is designed to keep breachers safe. Even in close quarters, the oversized control-flex handle system allows breachers to stand outside the "fatal funnel," in a safer position that provides better maneuverability and concealment. It is electrically non-conductive and non-sparking, resisting up to 100,000 volts AC. When speed is critical, you can count on this ram to get you and your unit through any door that stands in your way during breaching missions.

Features of Blackhawk Dynamic Entry CQB Ram

- Please note: This is a restricted item. To purchase, you must provide valid identification proving that you are a law enforcement, military or security professional
- Length: 20"
- Weight: 23 lbs
- Electrically non-conductive and non-sparking; resists up to 100,000 volts AC
- Oversized control-flex handle system

- Handles lightweight exterior doors and most interior doors
- Made in USA

Description



Blackhawk Dynamic Entry CQB Ram

Safely and efficiently breach doors with the Blackhawk Dynamic Entry CQB Ram. This 23-pound ram is able to take down lightweight exterior and most interior doors. It's more than resilient and powerful. This ram also is designed to keep breachers safe. Even in close quarters, the oversized control-flex handle system allows breachers to stand outside the "fatal funnel," in a safer position that provides better maneuverability and concealment. It is electrically non-conductive and non-sparking, resisting up to 100,000 volts AC. When speed is critical, you can count on this ram to get you and your unit through any door that stands in your way during breaching missions.

Features of Blackhawk Dynamic Entry CQB Ram

- Please note: This is a restricted item. To purchase, you must provide valid identification proving that you are a law enforcement, military or security professional
- Length: 20"
- Weight: 23 lbs
- Electrically non-conductive and non-sparking; resists up to 100,000 volts AC
- Oversized control-flex handle system
- Handles lightweight exterior doors and most interior doors
- Made in USA

PRODUCT VIDEOS

Dynamic Entry CQB



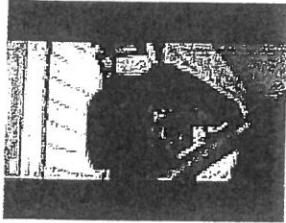

CUSTOMER REVIEWS

Blackhawk Dynamic Entry CQB Ram



(0 Reviews)

This product has not yet been reviewed.

[WRITE A REVIEW \(HTTP://TACTICALGEAR.COM/CUSTOMER-REVIEW?](http://tacticalgear.com/customer-review?PRODUCTID=3834&RETURNURL=http%3a%2f%2ftacticalgear.com%2fblackhawk-dynamic-entry-cqb-ram-black&ismodal=true)

[PRODUCTID=3834&RETURNURL=HTTP%3A%2F%2FTACTICALGEAR.COM%2FBLACKHAWK-DYNAMIC-ENTRY-CQB-RAM-BLACK&ISMODAL=TRUE\)](http://tacticalgear.com/customer-review?PRODUCTID=3834&RETURNURL=http%3a%2f%2ftacticalgear.com%2fblackhawk-dynamic-entry-cqb-ram-black&ismodal=true)

Enter City

State
Select State

Delivery Options

No-Rush (6 - 9 Business Days) - \$2.99

Standard (3 - 5 Business Days) - \$6.95

2 Business Days - \$56.02

1 Business Day - \$75.74

CONTINUE TO PAYMENT

You can review this order before it's final.

- 2 Payment
- 3 Account
- 4 Review

Cart Summary

| | |
|--------------|-----------------|
| Merchandise | \$245.99 |
| Shipping | \$2.99 |
| TOTAL | \$248.98 |

PLACE MY ORDER

TOWN OF NORTH HAMPTON
233 ATLANTIC AVENUE
NORTH HAMPTON, NH 03862



MICHAEL E. MADDOCKS
CHIEF

TELEPHONE
BUSINESS ----- (603) 964-8621
EMERGENCY ----- (603) 679-2225
-----9-1-1
FAX NO. ----- (603) 964-8831

POLICE DEPARTMENT

To: Mr. Paul Apple
From: Chief Michael E. Maddocks
Subject: Expenditure of Funds
Date: June 23, 2016

Please accept this request to be on the selectboard agenda in order to expend budget surplus for the purchase ammunition in the amount of \$2,196.66 with shipping.

The purchase of the ammunition would add to the inventory of duty ammunition for service and annual trainings and qualifications.

Respectfully,

Michael E. Maddocks

Product Quote

Eagle Point Gun/T. J. Morris & Son
 1707 Third Street
 Thorofare, New Jersey 08086
 p: 856.848.6945
 f: 856.384.2938
 e: majortjmorrisiii@comcast.net

Quote requested by: North Hampton Police
Requestor's phone:
Requestor's fax:
Requestor's email:
Requestor's zip:

| QUANTITY | CASE SIZE | ITEM NUMBER | ITEM DESCRIPTION | COST PER CASE | EXTENDED COST |
|----------|-----------|-------------|------------------------|---------------|---------------|
| 1 | 1,000 | 53368 | 357Sig 100gr Frangible | \$ 415.83 | \$ 415.83 |
| 3 | 1,000 | 54234 | 357Sig 125gr GDHP | \$ 400.05 | \$ 1,200.15 |
| 4 | 500 | AE223G | 223 cal 55 gr FMJ | \$ 143.92 | \$ 575.68 |
| | | | | | \$ - |
| | | | | | \$ - |
| | | | | | \$ - |
| | | | | | \$ - |
| | | | | | \$ - |
| | | | | | \$ - |
| | | | | | \$ - |
| | | | | | \$ - |
| | | | | | \$ - |

TOTAL = \$ 2,191.66

Notes: The above prices are pursuant to New Hampshire State Contract # 8001897, will hold until 30 SEP 2016, and include the freight drop shipped from the factory directly to your department, tailgate delivery. Should I happen to have any of the above in stock and you want it delivered out of my warehouse, I have to add freight to the above prices. There is no minimum or maximum order, but it is required that you order by the case. Assuming drop ship, should you decide on different quantities than listed, use the unit prices to determine your new totals. Drop ship lead times are running from 30-360 days ARO.

Quoted by: Brian Vare
Quote on: 22-Jun-2016

TOWN OF NORTH HAMPTON
233 ATLANTIC AVENUE
NORTH HAMPTON, NH 03862



POLICE DEPARTMENT

MICHAEL E. MADDOCKS
CHIEF

TELEPHONE
BUSINESS (603) 964-8621
EMERGENCY (603) 679-2225
 ---9-1-1
FAX NO. (603) 964-8831

To: Mr. Paul Apple
From: Chief Michael E. Maddocks
Subject: Expenditure of Funds
Date: June 23, 2016

Please accept this request to be on the selectboard agenda in order to expend budget surplus for the purchase of two (2) Motorola APX6500Li mobile cruiser radios in the amount of \$6,839.54 with shipping.

The purchase of the mobile cruiser radios would replace aging radios and be installed in the two new cruisers that will be purchased in Fiscal Year 2017.

Respectfully,

A handwritten signature in black ink, appearing to read "Michael E. Maddocks", is written over a horizontal line.

Michael E. Maddocks



Quote Number: QU0000366825
 Effective: 21 JUN 2016
 Effective To: 20 AUG 2016

Bill-To:

NORTH HAMPTON POLICE DEPT
 233 ATLANTIC AVE
 NORTH HAMPTON, NH 03862
 United States

Ultimate Destination:

NORTH HAMPTON POLICE DEPT
 233 ATLANTIC AVE
 NORTH HAMPTON, NH 03862
 United States

Attention:

Name: Chief Maddocks
Email: mmaddocks@northhampton-nh.gov
Phone: 603-964-8621

Sales Contact:

Name: Nicholas Hamel
Email: nhamel@2-way.biz
Phone: 603-431-6288

Contract Number: NASPO ValuePoint
Freight terms: FOB Destination
Payment terms: Net 30 Due

| Item | Quantity | Nomenclature | Description | Your price | Extended Price |
|------|----------|---------------|---|------------|----------------|
| 1 | 2 | M25KTS9PW1AN | APX6500 VHF HIGH POWER | \$2,094.37 | \$4,188.74 |
| 1a | 2 | G24AX | ADD: 3 YEAR SERVICE FROM THE START LITE | \$121.00 | \$242.00 |
| 1b | 2 | W22BA | ADD: PALM MICROPHONE | \$52.56 | \$105.12 |
| 1c | 2 | G442AJ | ADD: O5 CONTROL HEAD | \$315.36 | \$630.72 |
| 1d | 2 | G444AE | ADD: APX CONTROL HEAD SOFTWARE | - | - |
| 1e | 2 | G89AC | ADD: NO RF ANTENNA NEEDED | - | - |
| 1f | 2 | B18CR | ADD: AUXILIARY SPKR 7.5 WATT | \$43.80 | \$87.60 |
| 1g | 2 | Q811BS | DIGITAL CONVENTIONAL | \$474.50 | \$949.00 |
| 1h | 2 | W12DK | ADD: RF PREAMP | \$48.18 | \$96.36 |
| 2 | 2 | SVC03SVC0025D | POLICE TRUNK MNT RADIO INST ZONE 1 | \$270.00 | \$540.00 |

Total Quote in USD

\$6,839.54

THIS QUOTE IS BASED ON THE FOLLOWING:

1 This quotation is provided to you for information purposes only and is not intended to be an offer or a binding proposal.

If you wish to purchase the quoted products, Motorola Solutions, Inc. ("Motorola") will be pleased to provide you with our standard terms and conditions of sale (which will include the capitalized provisions below), or alternatively, receive your purchase order which will be acknowledged.

Thank you for your consideration of Motorola products.

- 2 Quotes are exclusive of all installation and programming charges (unless expressly stated) and all applicable taxes.
- 3 Purchaser will be responsible for shipping costs, which will be added to the invoice.
- 4 Prices quoted are valid for thirty(30) days from the date of this quote.
- 5 Unless otherwise stated, payment will be due within thirty days after invoice. Invoicing will occur concurrently with shipping.

MOTOROLA DISCLAIMS ALL OTHER WARRANTIES WITH RESPECT TO THE ORDERED PRODUCTS, EXPRESS OR IMPLIED INCLUDING THE IMPLIED WARRANTIES OF MERCHANTABILITY AND FITNESS FOR A PARTICULAR PURPOSE.

MOTOROLA'S TOTAL LIABILITY ARISING FROM THE ORDERED PRODUCTS WILL BE LIMITED TO THE PURCHASE PRICE OF THE PRODUCTS WITH RESPECT TO WHICH LOSSES OR DAMAGES ARE CLAIMED. IN NO EVENT WILL MOTOROLA BE LIABLE FOR INCIDENTAL OR CONSEQUENTIAL DAMAGES.

F A X

.....
2-Way Communications Service, Inc.
.....
.....
.....
.....
.....
.....

To: <6039648831>
Fax number: 6039648831

From: Christopher Tweedie
Fax number: 603-431-4832
Business phone: 800-441-6288 ext.1795
Home phone:

Date & Time: 6/22/2016 8:41:40 AM
Pages: 3
Re: Motorola Quote

Attn: Chief Maddocks

If you have any questions, please contact Nick Hamel at nhamel@2-way.biz

Thank you.

TOWN OF NORTH HAMPTON

233 ATLANTIC AVENUE
NORTH HAMPTON, NH 03862



MICHAEL E. MADDOCKS
CHIEF

TELEPHONE
BUSINESS ----- (603) 964-8621
EMERGENCY ----- (603) 679-2225
-----9-1-1
FAX NO. ----- (603) 964-8831

POLICE DEPARTMENT

To: Mr. Paul Apple
From: Chief Michael E. Maddocks
Subject: Expenditure of Funds
Date: June 23, 2016

Please accept this request to be on the selectboard agenda in order to expend budget surplus for the purchase of five (5) Driver Feedback Signs (solar powered) in the amount of \$14,200.00 with shipping.

The purchase of the driver feedback signs would enable three to be installed in an area identified as high traffic and high speeds and two to be used for a "seasonal speed limit zone." The driver feedback signs would also have data analysis and reports for total and average traffic counts, and minimum and maximum speeds.

Respectfully,

Michael E. Maddocks



Traffic Logix Inc.
 3 Harriet Lane, Spring Valley, NY 10977
 Tel: 1-866-915-6449
 Fax: 1-866-995-6449
 www.trafficlogix.com

SafePace™ 100
5 SIGN QUOTE
INVOICE
G-160622 5r2
TODAY'S DATE
6/23/2016

Q
U
O
T
E
T
O

Chief Michael E. Maddocks
 North Hampton Police Department
 233 Atlantic Avenue
 North Hampton, NH 03862
 603-964-2198 x-2241
 603-964-8831 (fax)

S
H
I
P
T
O

Attn.:

**WE PROVIDE MULTIPLE
 TRAFFIC CALMING SOLUTIONS**

COMMENTS
 Assumes 53ft Semi access , Dock and
 Forklift are available by client.

| | | |
|-----------------|-------------|---------------------------|
| CUSTOMER NUMBER | CUSTOMER PO | ACCOUNT MANAGER |
| | | MARK GREGORY |
| DATE ORDERED | SHIP VIA | MGREGORY@trafficlogix.com |
| | GRND | 1-518-744-8568 |

| PART NUMBER | DESCRIPTION | UNIT PRICE | EXTENSION |
|-------------|-------------|------------|-----------|
|-------------|-------------|------------|-----------|

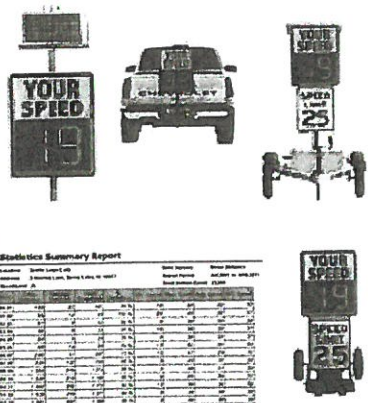
| | | | |
|--|-------------|--|--------------|
|  | | <p align="center">SafePace™ 100</p> <p>11" H Speed Digits - Variable Speed Settings - Detection Distance up to 500 Ft</p> <p>Armored Face Plate Sign - Fully Programmable Interactive Speed Display Speed Digits - Amber - Flash when designated speed is exceeded Sign powers down when no traffic present - Extends battery charge Programmable Center Mounted Speed Violator Flashing Stroble Light Weatherproof, non-sealed and ventilated protective enclosure Safe Pace Pro Management Software - Display Configuration 24/7 - 365 programing and scheduling; Variety of display settings "STEATH" Mode Option - Bluetooth Connectivity</p> <p>Included Included Included Included Included Included</p> <p>Cruiser Trailer Features</p> <p>2 Year Warranty - Powder Coat Finish - 12" Tires - Sealed Beam Lights Interchangeable SPEED LIMIT Numbers - Adjustable Jack Stands TorFlex Axle - Square Tube Frame Design - Telescoping Tongue Weathertight AC Recharge Hookup - Lockable Storage Box</p> | |
| Ordered | Part Number | Radior Sign Pricing | |
| 0 | SP1105E | SafePace™ 100 | \$ - |
| 0 | SP114EB | AC Power | \$ - |
| 5 | SP113ES | Battery Power 4 Cell Lithium Ion | \$ 2,279.00 |
| | | Solar Power * | \$ 11,395.00 |
| | | * Includes: 20W Solar Panel & Mounting Brackets, plus BACK-UP Battery | |
| | | ** AC Battery Charger Included with all Power Units | |
| | | Two Year Sign Warranty - One Year on Batteries | |

| Ordered | Part Number | Description: | Unit | Extension |
|---------|-------------|---|-------------|-------------|
| 5 | GSM | GSM Modem + Volume/Speed/85th% - by Hour/Day/Week | \$ 375.00 | \$ 1,875.00 |
| 0 | CLOUD | Web / CLOUD Access & Reports: Remote Access - 1 year - Unlimited | \$ 375.00 | \$ - |
| 0 | SPBA4 | Spare Batteries: 4 Cell Lithium Ion | \$ 325.00 | \$ - |
| 5 | SP1BK2 | Universal Mounting Bracket: Allows for Secure and Easy sign relocation. | \$ 115.00 | \$ 575.00 |
| 0 | SP1BK506 | Pole Plate: used in conjunction with Universal Mounting Bracket. | \$ 49.00 | \$ - |
| 0 | Cruiser LT | Cruiser Lt Trailer: - plus locking axle. | \$ 3,499.00 | \$ - |
| 5 | GSM ANTENNA | CLOUD Antenna: Allow connection via Cloud | \$ - | \$ - |
| 0 | SP1HIMNT | Truck Hitch Mount: Work Zone or Temporary / Limited Use Projects | \$ 300.00 | \$ - |
| 0 | SPDOLLY | Hand-Truck / Dolly: Mobil Cart - Industrial / Dock / Load-UnLoad Areas | \$ 690.00 | \$ - |
| 0 | DATA | Data Analysis & Reports: Volume/Speed/85th% - by Hour/Day/Week | \$ 400.00 | \$ - |

| | | | | |
|---|--|--|--|--------------|
| SHIPPING = 5 business days transit time with no special services | | | Sub Total | \$ 13,845.00 |
| *** If White face plate background is desired, must specify at time of order as Yellow is standard color. No charge for change. | | | Estimated Freight charges to SHIP TO ADDRESS | \$ 355.00 |
| SPECIAL | | | Freight Additions Totals: | |

Terms: 1% - 10 Days - Net 30 • We also accept: MC - VISA - AMEX - DISCOVER \$ 14,200.00

| | | | |
|----------------------|--|-----------------------------------|---------------------------|
| IF TAX EXEMPT | Please Provide Tax Exempt Certificate with Order | Prior to any Freight Additions | INVOICE TOTALS |
|----------------------|--|-----------------------------------|---------------------------|

SIGNATURE: _____ **DATE:** _____

Thank You for your order.

email to : MGREGORY@trafficlogix.com

*** COMPLETED BUSINESS APPLICATION IS REQUIRED FOR ALL NEW CUSTOMERS ***

TOWN OF NORTH HAMPTON
233 ATLANTIC AVENUE
NORTH HAMPTON, NH 03862



MICHAEL E. MADDOCKS
CHIEF

TELEPHONE
BUSINESS ----- (603) 964-8621
EMERGENCY ----- (603) 679-2225
-----9-1-1
FAX NO. ----- (603) 964-8831

POLICE DEPARTMENT

To: Mr. Paul Apple
From: Chief Michael E. Maddocks
Subject: Expenditure of Funds
Date: June 23, 2016

Please accept this request to be on the selectboard agenda in order to expend budget surplus for the purchase of two (2) Radar Trailers (solar powered) in the amount of \$13,098.00 with shipping.

The purchase of the radar trailers with SafePace 100 Feedback signs mounted on the trailers would enable the units to be deployed to areas where speed complaints have been received and where a radar trailer has been requested. The radar signs would also have data analysis and reports for traffic counts, and minimum and maximum speeds.



Traffic Logix Inc.
 3 Harriet Lane, Spring Valley, NY 10977
 Tel: 1-866-915-6449
 Fax: 1-866-995-6449
 www.trafficlogix.com

Q
U
O
T
E

Chief Michael E. Maddocks
 North Hampton Police Department
 233 Atlantic Avenue
 North Hampton, NH 03862
 603-964-2198 x-2241
 603-964-8831 (fax)

S
H
I
P
T
O

Attn:

SafePace™ 100
 with Data, with LT Trailer
INVOICE
G-160623 t1
 TODAY'S DATE
6/23/2016

**WE PROVIDE MULTIPLE
 TRAFFIC CALMING SOLUTIONS**

COMMENTS
 Assumes 53ft Semi access , Dock and
 Forklift are available by client.

| | | | |
|-----------------|-------------|---------------------------|--|
| CUSTOMER NUMBER | CUSTOMER PO | ACCOUNT MANAGER | |
| | | MARK GREGORY | |
| DATE ORDERED | SHIP VIA | MGREGORY@trafficlogix.com | |
| | GRND | 1-518-744-8568 | |

| PART NUMBER | DESCRIPTION | UNIT PRICE | EXTENSION |
|-------------|-------------|------------|-----------|
|-------------|-------------|------------|-----------|

| | | | | |
|---------|-------------|---|-------------|--|
| | | <p align="center">SafePace™ 100</p> <p align="center">11" H Speed Digits - Variable Speed Settings - Detection Distance up to 500 Ft</p> <p>Armored Face Plate Sign - Fully Programmable Interactive Speed Display Speed Digits - Amber - Flash when designated speed is exceeded Sign powers down when no traffic present - Extends battery charge Programmable Center Mounted Speed Violator Flashing Stroble Light Weatherproof, non-sealed and ventilated protective enclosure Safe Pace Pro Management Software - Display Configuration 24/7 - 365 programing and scheduling; Variety of display settings "STEATH" Mode Option - Bluetooth Connectivity</p> | | Included Included Included Included Included Included Included |
| | | <p>Cruiser Trailer Features</p> <p>2 Year Warranty - Powder Coat Finish - 12" Tires - Sealed Beam Lights Interchangeable SPEED LIMIT Numbers - Adjustable Jack Stands TorFlex Axle - Square Tube Frame Design - Telescoping Tongue Weathertight AC Recharge Hookup - Lockable Storage Box</p> | | |
| Ordered | Part Number | Radior Sign Pricing | | |
| 0 | SP1105E | SafePace™ 100 | \$ - | |
| 0 | SP114EB | AC Power | \$ - | |
| 2 | SP113ES | Battery Power 4 Cell Lithium Ion | \$ 2,400.00 | |
| | | Solar Power * | \$ 4,800.00 | |
| | | * Includes: 20W Solar Panel & Mounting Brackets, plus BACK-UP Battery | | |
| | | ** AC Battery Charger Included with all Power Units | | |
| | | Two Year Sign Warranty - One Year on Batteries | | |

| Ordered | Part Number | Description: | Unit | Extension |
|---------|-------------|---|-------------|-------------|
| 2 | GSM | GSM Modem + Volume/Speed/85th% - by Hour/Day/Week | \$ 375.00 | \$ 750.00 |
| 0 | CLOUD | Web / CLOUD Access & Reports: Remote Access - 1 year - Unlimited | \$ 375.00 | \$ - |
| 0 | SPBA4 | Spare Batteries: 4 Cell Lithium Ion | \$ 325.00 | \$ - |
| 0 | SP1BK2 | Universal Mounting Bracket: Allows for Secure and Easy sign relocation. | \$ 125.00 | \$ - |
| 0 | SP1BK506 | Pole Plate: used in conjunction with Universal Mounting Bracket. | \$ 49.00 | \$ - |
| 2 | Cruiser LT | Cruiser Lt Trailer: - plus locking axle. | \$ 3,399.00 | \$ 6,798.00 |
| 2 | GSM ANTENNA | CLOUD Antenna: Allow connection via Cloud | \$ - | \$ - |
| 0 | SP1HIMNT | Truck Hitch Mount: Work Zone or Temporary / Limited Use Projects | \$ 300.00 | \$ - |
| 0 | SPDOLLY | Hand-Truck / Dolly: Mobil Cart - Industrial / Dock / Load-UnLoad Areas | \$ 690.00 | \$ - |
| 0 | DATA | Data Analysis & Reports: Volume/Speed/85th% - by Hour/Day/Week | \$ 400.00 | \$ - |

| | | | | |
|---|--|--|--|--------------|
| SHIPPING = 5 business days transit time with no special services | | | Sub Total | \$ 12,348.00 |
| *** If White face plate background is desired, must specify at time of order as Yellow is standard color. No charge for change. | | | Estimated Freight charges to SHIP TO ADDRESS | \$ 750.00 |
| SPECIAL | | | Freight Additions Totals: | |

Terms: 1% - 10 Days - Net 30 • We also accept: MC - VISA - AMEX - DISCOVER \$ 13,098.00

| | | | |
|----------------------|--|--------------------------------|-----------------------|
| IF TAX EXEMPT | Please Provide Tax Exempt Certificate with Order | Prior to any Freight Additions | INVOICE TOTALS |
|----------------------|--|--------------------------------|-----------------------|

SIGNATURE: _____ **DATE:** _____

email to : MGREGORY@trafficlogix.com *Thank You for your order.*

*** COMPLETED BUSINESS APPLICATION IS REQUIRED FOR ALL NEW CUSTOMERS ***



[Home](#) > [productservices](#) > [speedtrailer](#)

SafePace Cruiser LT Compact Trailer

LIGHTWEIGHT FOR IMPROVED PORTABILITY
LESS THAN 3 MINUTE DEPLOYMENT
EASY TO TRANSPORT
INTERCHANGEABLE SPEED LIMIT NUMBERS

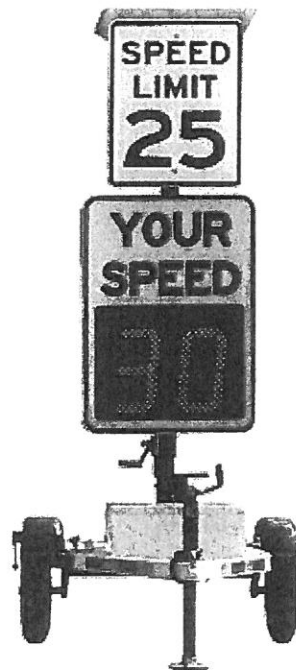

Get a Quote Now

[CLICK HERE](#)

[Features](#)

[Specifications](#)

[Options](#)

[Media](#)

[Software](#)

[Catalog](#)

The SafePace Cruiser LT speed trailers are lightweight, economical radar trailers with all the features you need for portable speed control. The versatile speed trailers deploy in less than 3 minutes with a simple crank that allows you to raise and lower the sign face. The radar sign can also be rotated in any direction, allowing you to park the speed trailer in any position and turn the sign face toward traffic. During travel, the sign is rotated for wind protection. A speed limit sign with changeable numbers ensures that your SafePace Cruiser speed trailers are ready to slow motorists, no matter what the speed limit. To see more photos of the SafePace Cruiser radar trailer, view our photo galleries.

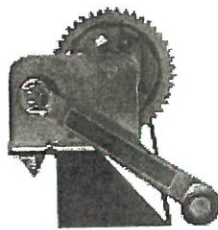

Intuitive design

Simple crank system make the speed trailers easy to deploy, tow, and transport



Quick and easy deployment

Less than 3 minute deployment by single operator for quick and easy setup at multiple locations

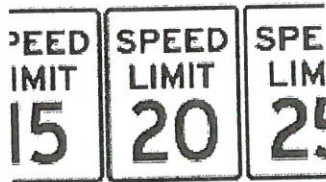

Interchangeable speed limit numbers

The included speed limit sign has interchangeable numbers so that you can change the speed limit as often as you need when rotating the trailer to multiple locations

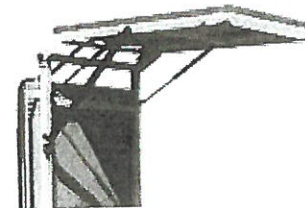

Top mounted solar panel

Optional solar panel offers power efficiency for your speed sign trailer

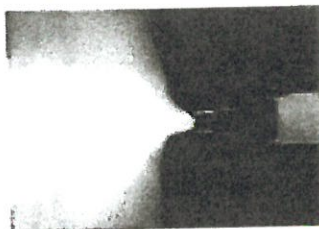

Rust proof

Enamel coated finish for rust-proof protection

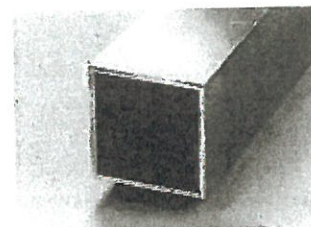

Built to last

Square tubing sign frame for extra strength



Easy to transport

Torflex axle ensures a soft, cushioned ride

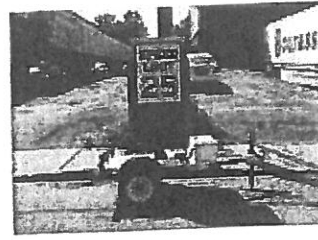

Variety of usages

Ideal for rotating usage in high traffic neighborhoods, school zones, hazard zones, short term work zones, or for special events



Cost effective

Allows for usage at multiple locations with limited maintenance for years of continuous use



Two year warranty

Two year warranty on parts and labor excluding damage related to vandalism, abuse, and/or theft

Reprinted from trafficlogix.com/productservices/speedtrailer.
Site contents are ©2016. All rights reserved.

TrafficLogix Corporation 3 Harriett Lane, Spring Valley, NY 10977 USA

Site by 

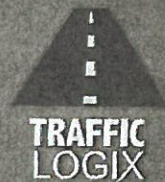

SafePace® Cruiser LT Rotating Speed Trailer

The SafePace Cruiser LT trailer allows you to use your SafePace sign for traffic calming on the go.

The unique Cruiser LT allows you to rotate your SafePace sign, eliminating the need for precise parking and protecting the sign face during travel. When used with the SafePace 800, the Cruiser LT allows for vertical or horizontal sign display. Built to last, the compact, affordable Cruiser LT trailer will let you get the most out of your SafePace signs.

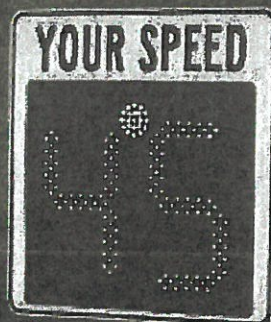

Cruiser LT Specifications

| | |
|------------------------------|-------------|
| Width | 51" |
| Length | 92" |
| Height in deployed position | 118" |
| Travel Height, down position | 77" |
| Weight | 425 lbs |
| Tire Size | 12" |
| Trailer lights | Sealed Beam |
| Warranty | 2 Years |

Features

| |
|---|
| Can be deployed in under 3 minutes by a single operator |
| Ideal for rotating in high traffic neighborhoods, school zones, work zones, or for special events |
| Low profile and light weight makes it easy to tow and transport |
| Rotating system allows you to direct sign toward traffic and protects face during travel |
| Displays sign vertically or horizontally when used with SafePace 800 sign |
| Polyester powder coat finish for rust-proof protection |
| Compatible with all SafePace signs |
| Torflex axle for cushioned ride |
| Interchangeable speed limit sign included |
| Limited maintenance, cost effective solution for years of continuous use |



🏠 > productsservices > safepace100

SafePace® 100 Compact Entry-Level Speed Sign

REMARKABLY PRICED
LIGHTWEIGHT AND PORTABLE
ENERGY EFFICIENT TECHNOLOGY
UNIVERSAL MOUNT

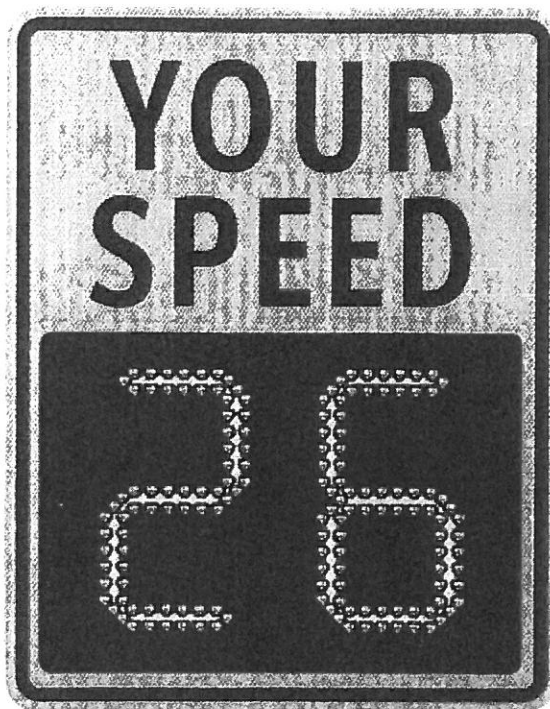

Get a Quote Now

[CLICK HERE](#)

[Features](#)

[Specifications](#)

[Options](#)

[Media](#)

[Software](#)

[Catalog](#)

Specifications

[Download the full spec sheet \(Legacy version\)](#)

[Download the full spec sheet \(Current version\)](#)

Dimensions

- Digit: 11"(h) x 5.6"(w), 98 LEDs per digit
- Unit alone: 15.8"(h) x 21.4"(w) x 3.5"(d)
- Unit with "YOUR SPEED" sign mounted:
 - Full size sign: 29.0"(h) x 23.0"(w) x 3.5"(d)
- Sign Weight (includes "YOUR SPEED" sign (2 lbs) mounted)
 - AC Powered Model: 21 lbs
 - 3 Cell Battery Powered Model: 23 lbs
 - 4 Cell Battery Powered Model: 25 lbs
 - Solar Powered Model: 23 lbs (does not include solar panel or bracket)
- Accessories
 - 3 Cell Lithium Ion Battery: 2 lbs
 - 4 Cell Lithium Ion Battery: 4 lbs
 - Universal Mounting Bracket System
- Sign Bracket: 2 lbs
- Pole Bracket: 5 lbs

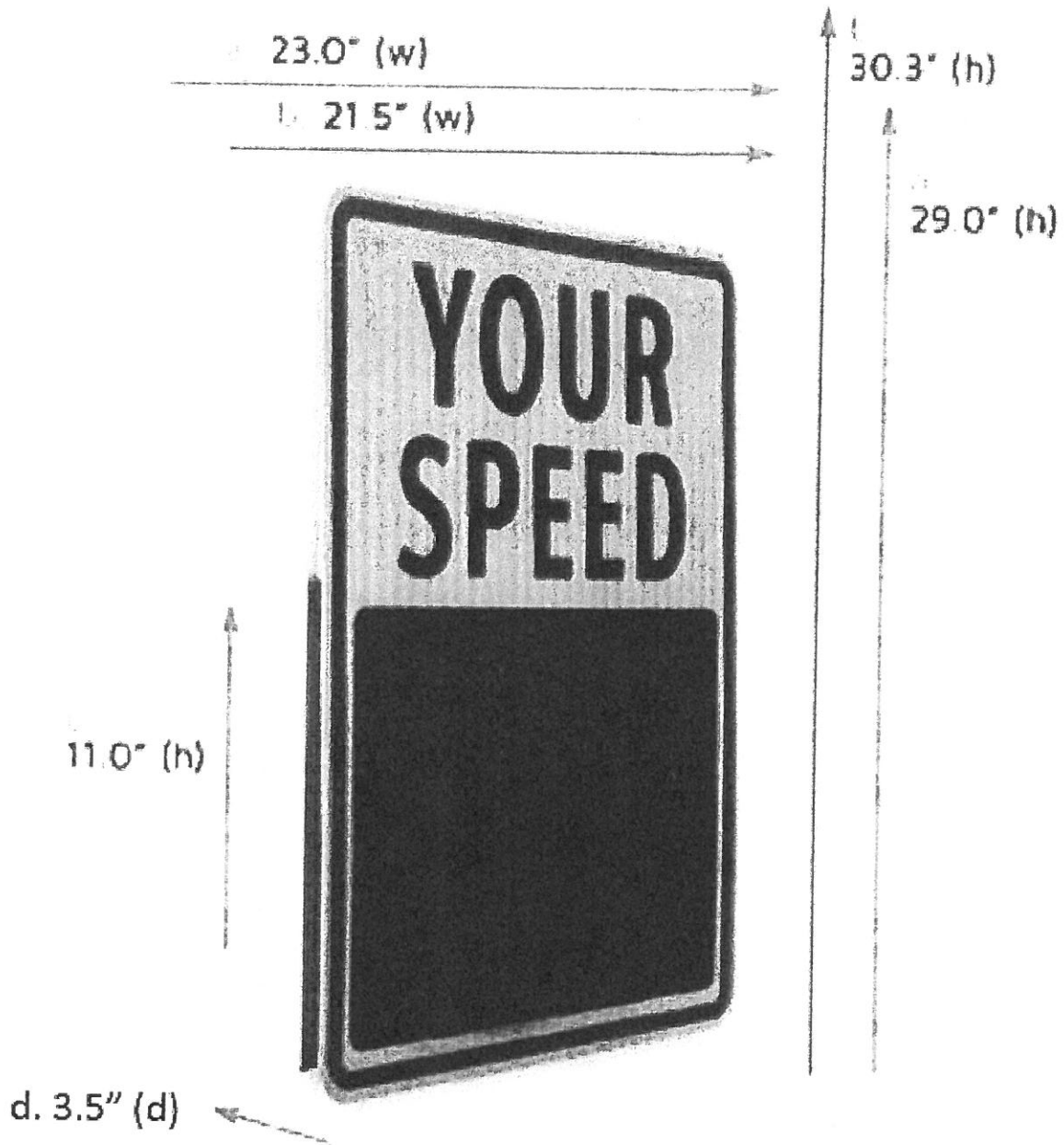

SafePace® 100 Full-size sign dimensions

Dimensions of SafePace® 100 Radar Sign with Full "YOUR SPEED" Sign Face



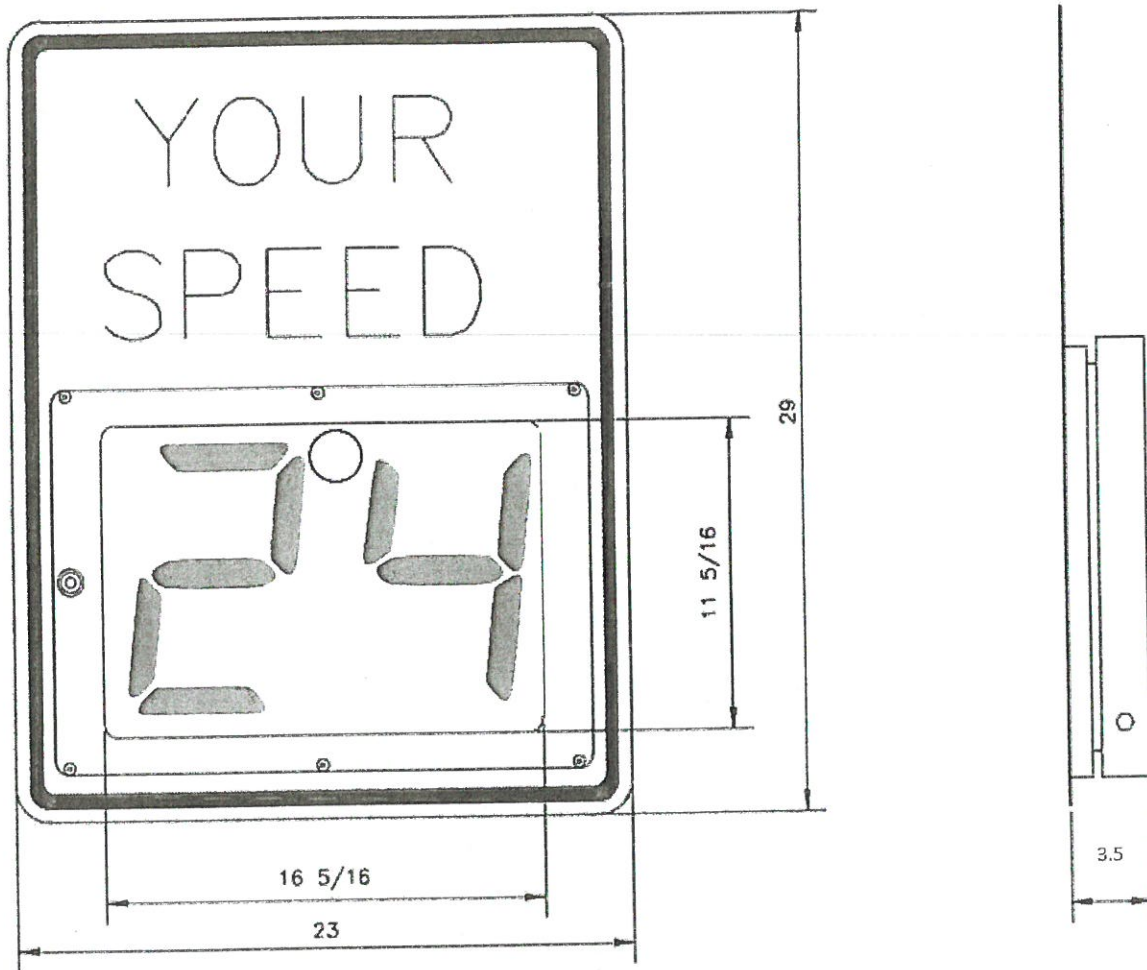

Dimensions of SafePace® 100 Radar Sign unit alone

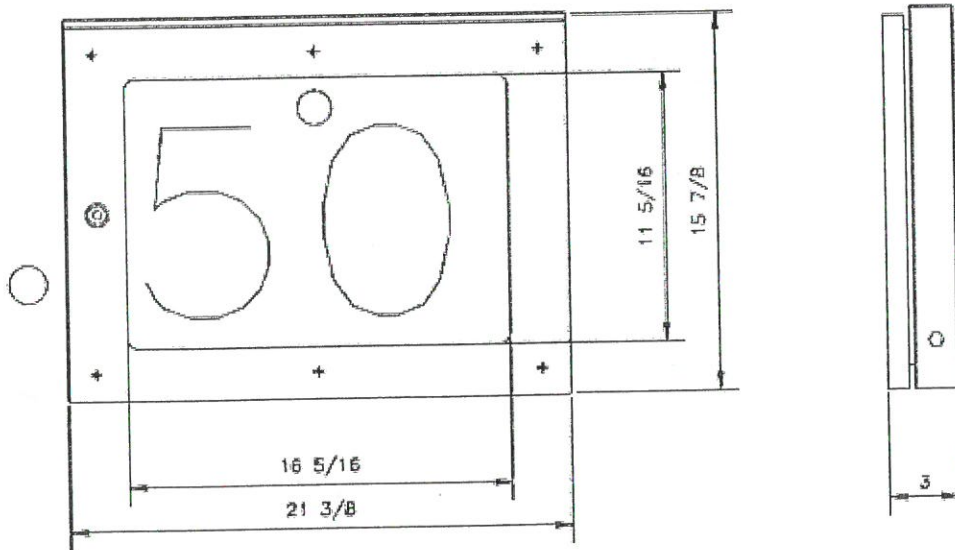

Technical Specifications

- Miles Per Hour (mph) or Kilometers Per Hour (km/h)
- Aluminum protective cover: 0.25" (d)

- High-Intensity prismatic reflective sheeting on "YOUR SPEED" signs with black colored text
- MUTCD approved colors and format
- Operating Temperatures F (C): -40° (-40°) to 185° (85°)
- Conformal coating on all circuit boards
- Power
 - Power input:
 - AC 90~264 VAC
 - 12 VDC
 - Vcc: 5.5 VDC to 16 VDC (18V max)
 - Icc@12 VDC (radar always on): Display blank- 9.5 mA
 - Display at night: 21 mA
 - Display max bright: 415 mA
 - Radar RF out: 5 mW maximum
 - Power Efficiency:
 - Best in class power efficiency
 - Low power SS300 radar drives display eliminate extra CPU
 - Built in ambient light sensing and automatic brightness control
 - Ambient temperature compensation of LED drive voltage
 - High efficiency boost regulator for LED drive voltage
 - With no traffic present, radar automatically powers down display, reducing power consumption to 0.1W
 - Power Options
 - AC power input: 90~264 VAC
 - DC power input: 12 VDC
 - Battery power option offers extended life:
 - - 3 Cell, 9.6V, 10Ah Lithium-Ion Phosphate battery with up to 2 weeks operation between charges (under normal operating conditions)
 - - 4 Cell, 12.8V, 15Ah Lithium-Ion Phosphate battery with up to 4 weeks operation between charges (under normal operating conditions)
 - Solar power
 - - Compact, 20W solar panel (15.4" x 9.8" x 0.71")
- Radar
 - Internal Radar: SS300 Doppler (FCC approved)
 - Radar RF out: 5 mW maximum
 - Radar f-center: 24.125 GHz or 24.200 GHz
 - Pickup distance: Up to 300 feet
 - Beam angle: 38 x 45
 - Beam polarization: Linear
 - CE Mark (Radar): Yes
- Display
 - LEDs 208:
 - Digits: 196 Amber, 15°, 5 mm, luminous Intensity (4180 - 8200)

- Speed Violator Strobe: 12 White, 15°, 5 mm , luminous intensity (4180 - 8200)
- Optical lenses: 208 lenses
- Display Brightness:
 - 11,000 nits (cdm) maximum
 - 550 nits (cdm) at night
- Ambient light sensor and automatic brightness adjustment
- Enclosure
 - 12 gauge aluminum, flat black powder coated front for reduced glare and maximum contrast; light gray powder coated body to minimize heat absorption
 - Weatherproof, NEMA 4X-12, IP65 level compliant
 - Non-sealed and ventilated

Communication

- **Bluetooth (standard)**
- **GSM/GPRS (additional option, for use with SafePace Cloud)**



Programming

- SafePace® Pro Management Software application
- Display Settings:
 - Display On/Stealth Modes (In Stealth Mode, speed is not displayed but data is collected)
 - Display Minimum Speed, Display Maximum Speed
 - Digit Flashing Speed Threshold (digits flash above selected speed)
 - Speed Violator Strobe (pulsing strobe flashes with digits or alone above Display Maximum Speed)

Data Collection and Statistical Analysis & Reporting (optional feature)

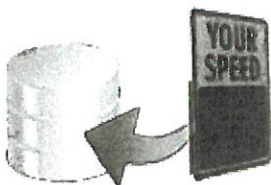

- Traffic data collected and stored by location
- Stealth Mode (capture baseline traffic data with speed display off)
- Download through Serial Port connection
- Statistical Reporting & Charts

- Summary Reports
- Weekly Reports
- Period Comparison Reports
- Reporting Parameters:
 - Average Vehicle Count
 - Total Vehicle Count
 - Average Speed
 - Average Number of Speed Violations
 - Total Number of Speed Violations
- Other Features:
 - Minimum and Maximum Speed
 - 85% Speed
 - Counters by Speed Bins
 - 5 MPH Bin Resolution
 - Reports print directly or can be exported into CSV format, MS Excel, Adobe Acrobat PDF and HTML
 - Charts may be printed directly or converted into Adobe Acrobat PDF and picture formats

Mounting Options

- Standard mounting bracket system (use banding brackets to fasten sign to steel or wooden pole)
- Universal Mounting Bracket System
 - Universal mounting options: circular, square and telspar poles
 - Theft resistant
 - Promotes sign portability: sign locks into mounting bracket with a turn of a key
- Sign dolly mounting system
 - Battery-powered sign recommended
 - Speed limit face plate not included
- Sign mounted to /compatible with SafePace Cruiser LT Lightweight Trailer
 - Battery box storage not included with trailer
 - See web-site trailer specifications for more details



Universal Mounting Bracket System

Bottom View

Locking Key

Pole Bracket

Sign Bracket

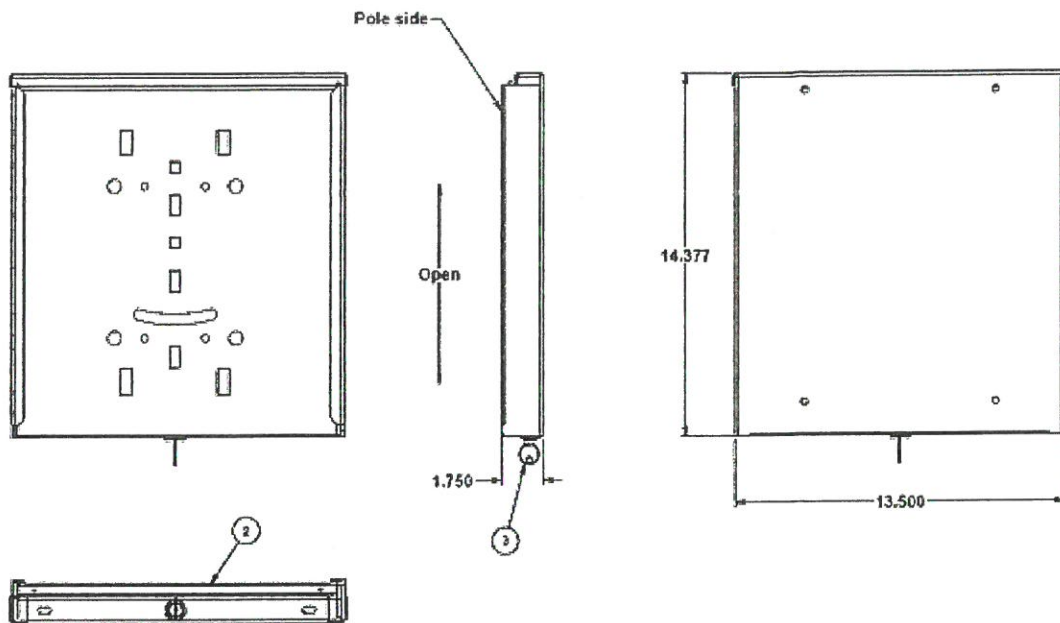

Inside View of Pole Bracket

Inside view

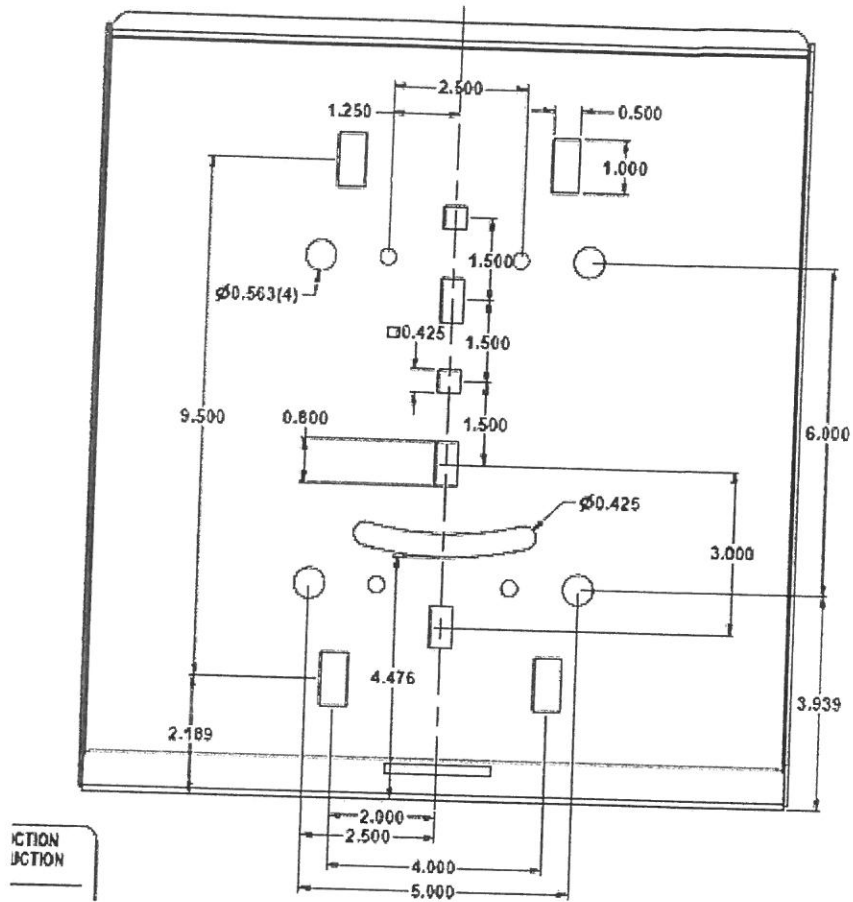

SafePace® 100 Solar Panel Specifications (p/n: SPS1500)

20 WATT Panel Specifications

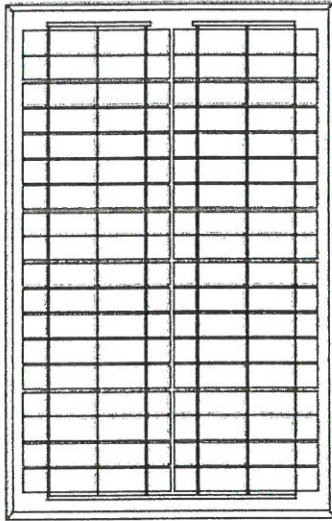

Solar cells: Crystalline solar cells

Laminate: Glass /EVA / TPT (tedlar/pet/tedlar) or TPE

Front Side: High-transmission 3.2mm tempered glass

Back Side: TPT /TPE

Frame: Clear anodized aluminum frame

Output: Junction box

| Module Type | Pm(Wp)±5% | Vmpp(V) | Impp(A) | Voc(V) | Isc(A) | Module size(mm) | NET(kg) |
|---------------|-----------|---------|---------|--------|--------|----------------------------------|---------|
| 20 WATT PANEL | 20 | 17.1 | 1.17 | 21.4 | 1.3 | 520*350*18mm 20.5"*13.8"*0.7" | 2.0 |

Operation Temperature Range: - 40°C~85°C

NOCT: 48±3°C

Temperature coefficients of Im: + 0.1 %/°C

Temperature coefficients of Vm: - 0.38 %/°C

Maximum System Voltage: DC600V

STC: 1000W/m², 25°C AM1.5

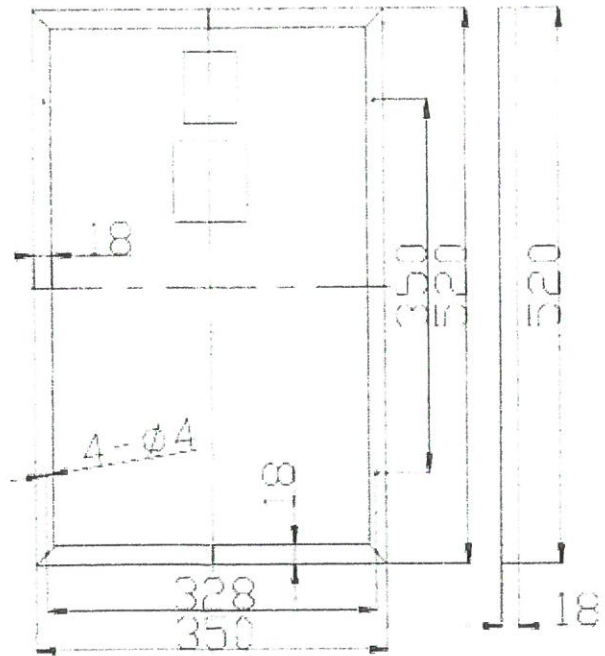

Reprinted from trafficlogix.com/productservices/safespace100.
Site contents are ©2016. All rights reserved.

TrafficLogix Corporation 3 Harriett Lane, Spring Valley, NY 10977 USA

Site by 

Jim Maggiore, Chair
Larry Miller, Vice Chair
Rick Stanton, Member



Municipal Offices
233 Atlantic Avenue
North Hampton, NH 03862

Tel: (603) 964-8087
Fax: (603) 964-1514

TOWN OF NORTH HAMPTON, NEW HAMPSHIRE
THE SELECT BOARD

MOTIONS IN RE FIRE DEPARTMENT PURCHASES

*PURCHASED
IN JUNE*

1. I move to encumber the sum of \$10,776.04.00 from the FY 2016 Operating Budget for the purpose of ~~purchasing radios, pursuant to a contract with Two-Way Communications Service, Inc. of Newington, New Hampshire dated June 20, 2016.~~

*PURCHASED
IN JUNE*

2. I move to encumber the sum of \$2,150.00 from the FY ~~2016~~ Operating Budget for the purpose of ~~purchasing rescue tools pursuant to a contract with Fire Tech & Safety of New England, Inc. of Tyngsboro, Massachusetts dated June 20, 2016.~~

3. I move to encumber the sum of \$18,248.00 from the FY 2016 Operating Budget for the purpose of purchasing a fire gear extractor and dryer, pursuant to a contract with Bergeron Protective Clothing, LLC, of Epsom, New Hampshire dated June 11, 2016.

\$ 31,174.04 TOTAL

(12,926.04) FY16

\$ 18,248.00 ENCUMBERED

*RA Stanton
Jim Maggiore
L Miller*

6-27-16

North Hampton Fire & Rescue

**2015/2016 Encumbrance
Requests**



North Hampton
FIRE & RESCUE

235 ATLANTIC AVENUE
NORTH HAMPTON, N.H. 03862

Michael J. Tully
CHIEF OF DEPARTMENT

TEL: (603) 964-5500
FAX: (603) 964-7249
EMERGENCY: 911

Truck Radios – \$10,776.04

Encumber

Thermal Imager Battery - \$135.00

Flashlights - \$785.70

Dining Chairs – \$1211.00

Office Chairs - \$528.00

Rescue Tools - \$2150.00

Encumber

Dispatch Monitor - \$129.99

Fire Gear Extractor/Dryer with accessories - \$18,247.50

Encumber

Total Requested - \$33,963.23

"Quality Service for a Quality Community"



North Hampton
FIRE & RESCUE

235 ATLANTIC AVENUE
NORTH HAMPTON, N.H. 03862

Michael J. Tully
CHIEF OF DEPARTMENT

TEL: (603) 964-5500
FAX: (603) 964-7249
EMERGENCY: 911

To: Mr. Paul Apple
From: Chief Michael Tully
Subject: Encumbrance of Funds
Date: 6/20/2016

Please accept this request to be on the select board agenda in order to transfer \$10,776.04 from FY 2015/2016 line item 1-4220-10-120 (Salary) to FY 2016/2017 line item 1-4220-10-572 (Radio Maintenance).

This will allow two radios to be purchased and installed in Engine 1 and the Ambulance.

Respectfully,

Michael J. Tully



Quote Number: QU0000366583
Effective: 20 JUN 2016
Effective To: 19 AUG 2016

Bill-To:
 NORTH HAMPTON FIRE DEPT
 235 ATLANTIC AVE
 NORTH HAMPTON, NH 03862
 United States

Ultimate Destination:
 NORTH HAMPTON FIRE DEPT
 235 ATLANTIC AVE
 NORTH HAMPTON, NH 03862
 United States

Attention:
Name: Martin Tavitian
Phone: 603-964-5500

Sales Contact:
Name: Nicholas Hamel
Email: nhamel@2-way.biz
Phone: 603-431-6288

Contract Number: NASPO ValuePoint
Freight terms: FOB Destination
Payment terms: Net 30 Due

| Item | Quantity | Nomenclature | Description | Your price | Extended Price |
|------|----------|---------------|---|------------|----------------|
| | | | | \$2,094.37 | \$4,188.74 |
| 1 | 2 | M25KTS9PW1AN | APX6500 VHF HIGH POWER | \$375.95 | \$751.90 |
| 1a | 2 | G806BE | ADD: ASTRO DIGITAL CAT OPERATION | \$315.36 | \$630.72 |
| 1b | 2 | G442AJ | ADD: OS CONTROL HEAD | \$52.56 | \$105.12 |
| 1c | 2 | W22BA | ADD: PALM MICROPHONE | \$121.00 | \$242.00 |
| 1d | 2 | G24AX | ADD: 3 YEAR SERVICE FROM THE START LITE | \$18.25 | \$36.50 |
| 1e | 2 | G610AC | ADD: REMOTE MOUNT CBL 30 FEET | \$10.95 | \$21.90 |
| 1f | 2 | G628AC | ADD: REMOTE MOUNT CBL 17 FEET | - | - |
| 1g | 2 | G444AE | ADD: APX CONTROL HEAD SOFTWARE | - | - |
| 1h | 2 | G89AC | ADD: NO RF ANTENNA NEEDED | \$43.80 | \$87.60 |
| 1i | 2 | G831AD | ADD: SPKR 15W WATER RESISTANT | \$365.00 | \$730.00 |
| 1j | 2 | G48BD | ENH: CONVENTIONAL OPERATION APX6500 | \$416.10 | \$832.20 |
| 1k | 2 | GA00092AC | ADD: DUAL-CONTRL HD HARDWARE | \$48.18 | \$96.36 |
| 1l | 2 | W12DK | ADD: RF PREAMP | \$1.00 | \$1,600.00 |
| 2 | 1600 | SVC03SVC0124D | SUBSCRIBER INSTALL - CUST LOCATION | | |

(Notes)Includes Swivel Mount for Front Control Head

\$9,323.04

Total Quote in USD

THIS QUOTE IS BASED ON THE FOLLOWING:

1 This quotation is provided to you for information purposes only and is not intended to be an offer or a binding proposal.

If you wish to purchase the quoted products, Motorola Solutions, Inc. ("Motorola") will be pleased to provide you with our standard terms and conditions of sale (which will include the capitalized provisions below), or alternatively, receive your purchase order which will be acknowledged.

Thank you for your consideration of Motorola products.

2-Way Communications Service, Inc.
23 River Road
Newington, NH 03801



Proposal
25171
 Date: 6/20/2016

Name / Address:

North Hampton Fire Department
 233 Atlantic Avenue
 North Hampton, NH 03862

"Your mission is our purpose."

Phone : 1-800-441-6288

Fax : 603-431-4832

E-mail us : FleetDivision@2-way.biz

Visit our Web Site : www.2-way.biz



| | |
|-----------|------|
| P.O. No.: | Rep: |
| | 798 |

| Qty | Item | Description | Total |
|-----|-----------|---|--------|
| 1 | MR-52X | Remove ASTRO Spectra Radio from Chief's Car, Install customer provided ASTRO Spectra or XTL/APX Mobile in Chief's Car. Provide Bluetooth Mics and Firecom Cable | |
| 2 | RLN6551 | Mobile radio interface cable - radio specific (APX/XTL) | 195.00 |
| 1 | HP4 | Motorola XPR Mobile Series Long Range Bluetooth Microphone. | 898.00 |
| 1 | Fleet Std | 12VDC Charger | 20.00 |
| | | Misc Installation Hardware Materials | |
| | | Fleet Division Standard Labor. | 340.00 |

2-Way Fleet Division is your full-time, factory trained Vehicle Upfitter.

Providing quality Service since 1954.

Thank you for choosing 2-Way. We are proud to service your fleet.

Subtotal \$1,453.00

Sales Tax (0.0%) \$0.00

Total \$1,453.00

Signature _____

- 2 Quotes are exclusive of all installation and programming charges (unless expressly stated) and all applicable taxes.
- 3 Purchaser will be responsible for shipping costs, which will be added to the invoice.
- 4 Prices quoted are valid for thirty(30) days from the date of this quote.
- 5 Unless otherwise stated, payment will be due within thirty days after invoice. Invoicing will occur concurrently with shipping.

MOTOROLA DISCLAIMS ALL OTHER WARRANTIES WITH RESPECT TO THE ORDERED PRODUCTS, EXPRESS OR IMPLIED INCLUDING THE IMPLIED WARRANTIES OF MERCHANTABILITY AND FITNESS FOR A PARTICULAR PURPOSE.

MOTOROLA'S TOTAL LIABILITY ARISING FROM THE ORDERED PRODUCTS WILL BE LIMITED TO THE PURCHASE PRICE OF THE PRODUCTS WITH RESPECT TO WHICH LOSSES OR DAMAGES ARE CLAIMED. IN NO EVENT WILL MOTOROLA BE LIABLE FOR INCIDENTAL OR CONSEQUENTIAL DAMAGES.



DIVISION OF FORESTS AND LANDS
172 Pembroke Road, Concord, New Hampshire 03301

November 16, 2015

RECEIVED
NOV 20 2015

603-271-2214
FAX: 603-271-6488
www.nhdfi.org

Michael Tully
Town of North Hampton
235 Atlantic Ave
North Hampton NH 03862

Dear Mr. Tully,

Your town has been awarded 2016 Volunteer Fire Assistance funds, as specified in the enclosed Memorandum of Understanding (MOU). In order to satisfy state and federal fiscal requirements, your community must match the amount of this grant. (For example if your town received \$500.00 in grant money, you must show expenditures of at least \$1,000.00.) You must come up with the total grant amount and we will reimburse you at 50%. You cannot use other federal funds for the 50% match. The amount shown on the enclosed MOU is the amount of grant money your town has been awarded.

The enclosed Memorandum of Understanding (MOU) must be signed and the **original** returned to our office before checks are mailed out. We require the MOU to be signed and returned within 30 days of this letter so we know that these funds are committed. No checks will be sent out until we receive the MOU, bill of sale/invoice for all items and copy of cancelled check(s) or bank statement.

Please note what is to be purchased with these funds:

These funds can only be utilized to purchase the items listed on the MOU

****Please note that if a item is available in GSA that is the price we will use to cost share****

**** Beginning this year, we are required to obtain from each fire department the Financial Capability Checklist for Grants and Cooperative Agreements. Please fill out and return with your signed MOU****

To place an order with the Town Tools Program, visit our website at: <http://www.nhdfi.org/fire-control-and-law-enforcement/community-fire-assistance/> to obtain the order form. Please follow the directions on the form.

If the original purchase and reimbursement for these items is from community (town/city) funds, all should be okay for reimbursement. If the purchase funds/reimbursement is to another organization (firemen's association, etc.) we need to know that so the reimbursement check is made out correctly. This alternative organization shall have a tax ID number and will be required to complete an Alternate W-9 Form to set up a vendor account with the State of New Hampshire.

A copy of your Town's cancelled check(s) and paid invoice(s) needs to be sent to us no later than August 31, 2016. If they are not received by that date, the funds will be de-obligated.

If you have any question, please do not hesitate to contact Leslie Sherman by phone at 271-2214 or by email leslie.sherman@dred.nh.gov

Enclosures:
Town Application (Copy)
MOU
Financial Capability Checklist

Sincerely,

Brad W. Simpkins, Director



TDD ACCESS: RELAY NH 1-800-735-2964  recycled paper

DIVISION OF FORESTS AND LANDS 603-271-2214

Concord NH 03301
Memorandum of Understanding
For State Assistance
Volunteer Fire Assistance
2016

In consideration of the performance of the terms and conditions hereinafter set forth, the State of New Hampshire, Department of Resources and Economic Development, Division of Forests and Lands, hereby awards TO: Town of North Hampton FOR: Porta-mobile radio for engine; Hereafter called the recipient, the SUM of \$ 2000.00 pursuant to the provisions of the Rural Development Act of 1972 (P.L. 92-419, Title IV) upon the following terms and conditions:

1. **EXPENDITURES.** The sum hereinbefore mentioned, or any part of it, shall be spent only for supplies, equipment or services listed as "Items" on the previously submitted, now approved, application for assistance and no others, without the express written consent of the Director, Division of Forests and Lands or his agent.
2. **MATCHING FUNDS.** The recipient shall provide an amount equal to or greater than the State's award to fund the expenditures authorized in Section 1, in such form and at such times as the Division of Forests and Lands may direct. The State 50% is a reimbursement.
3. **FEDERAL LAW.** The recipient shall, in good faith, abide by all applicable federal laws, rules, regulations and guidelines in the performance of its obligations hereunder.
4. **REPORTS.** The Division shall have access to and the right to examine all records, books, papers and documents related to this grant for at least three (3) years after completion of the project. A final report on the expenditure of the project funds shall be submitted, together with copies of warrant numbers, receipts and other evidences of expenditures, to the Division within 30 days after the completion of the project.
5. The State retains the right to place a property inventory tag on any items purchased with these funds and retains the right to inspect this property for duration of its life.
6. **UNEXPENDED FUNDS.** The recipient shall return any unexpended funds under this grant to the State, by check made out to the Treasurer, State of New Hampshire and delivered to the office of the Director, Division of Forests and Lands, no later than 30 days after the completion of the project.
7. **PERFORMANCE.** The recipient shall return to the State, in this manner prescribed in Section 1, any funds advanced under this agreement upon the written demand of Director, Division of Forests and Lands, when in his sole discretion, he determines that there has been a breach of this Memorandum of Understanding or any of its terms or the performance of the recipient or any contractor receiving funds under this grant is unsatisfactory by reason of failure to provide equipment of services reasonably adequate to meet the fire protection needs under this grant in a timely manner.
8. **LIABILITY.** The recipient agrees to defend or cause to be defended and to indemnify and hold the State of New Hampshire harmless against any and all claims, suits, damages or causes of action for damages and against any orders, decrees, or judgments which may be entered thereon, brought for damages or alleged damages from any injury, for any injury to person or property of loss of life sustained in any manner arising out of the performance of this agreement, or where such damages or alleged damages are attributable to acts of employees, contractors, or agents of the recipient.

By _____
Director, Division of Forests and Lands

By Chris Mulvaney
Forest Fire Warden

Dated this 23rd day of November 20 15



North Hampton
FIRE & RESCUE

235 ATLANTIC AVENUE
NORTH HAMPTON, N.H. 03862

Michael J. Tully
CHIEF OF DEPARTMENT

TEL: (603) 964-5500
FAX: (603) 964-7249
EMERGENCY: 911

To: Mr. Paul Apple
From: Chief Michael Tully
Subject: Encumbrance of Funds
Date: 6/21/2016

Please accept this request to be on the select board agenda in order to transfer \$135.00 from FY 2015/2016 line item 1-4220-10-571 (Equipment Maintenance) to FY 2016/2017 line item 1-4220-10-572 (Equipment Maintenance).

This will allow for the purchase of a new battery for the Thermal Imager.

Respectfully,

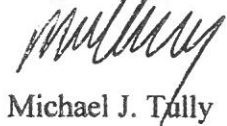

Michael J. Tully



**FIRE TECH & SAFETY
OF NEW ENGLAND INC.**

90 Progress Ave
Tyngsboro, MA 01879

978-649-6800

1-800-256-8700 FAX (978) 649-6833

QUOTATION

PLEASE INDICATE THE ABOVE NUMBER WHEN ORDERING

TO **North Hampton Fire Department**
235 Atlantic Ave
North Hampton, NH 03862

| | |
|----------------|-----------------|
| QUOTATION DATE | SALESPERSON |
| 6/20/2016 | Craig Robichaud |
| INQUIRY DATE | |

| ESTIMATED SHIPPING DATE | SHIPPED VIA | F.O.B. | TERMS | |
|-------------------------|-----------------------|--------|------------|--------|
| QUANTITY | DESCRIPTION | | UNIT PRICE | AMOUNT |
| 1 | Bullard T3/T4 Battery | | \$135.00 | |
| | | | TOTAL | |

WE ARE PLEASED TO SUBMIT THE ABOVE QUOTATION FOR YOUR CONSIDERATION. SHOULD YOU PLACE AN ORDER, BE ASSURED IT WILL RECEIVE OUR PROMPT ATTENTION. THIS QUOTATION IS VALID FOR 30 DAYS THEREAFTER IT IS SUBJECT TO CHANGE WITHOUT NOTICE

QUOTED BY: FIRE TECH SAFETY ACCEPTED _____ DATE: _____

PLEASE SIGN AND RETURN A COPY WHEN ORDERING

THANK YOU!



North Hampton
FIRE & RESCUE

235 ATLANTIC AVENUE
NORTH HAMPTON, N.H. 03862

Michael J. Tully
CHIEF OF DEPARTMENT

TEL: (603) 964-5500
FAX: (603) 964-7249
EMERGENCY: 911

To: Mr. Paul Apple
From: Chief Michael Tully
Subject: Encumbrance of Funds
Date: 6/21/2016

Please accept this request to be on the select board agenda in order to transfer \$785.70 from FY 2015/2016 line item 1-4220-10-120 (Salary) to FY 2016/2017 line item 1-4220-10-740 (Equipment).

This will allow nine flashlights to be purchased for use on the apparatus.

Respectfully,

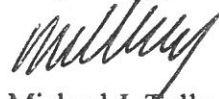

Michael J. Tully

QUOTATION

No. : **200666**



1024 Suncook Valley Hwy., Unit 5-D
Epsom NH, 03234
TEL: 603.736.8500
www.BergeronProtectiveClothing.com

Doc. Date : 06/20/2016
Payment Terms : NET30
Valid Until: 09/01/2016
Customer PO:
Salesperson : Maureen Gnecco
Page : Page 1 of 1

Bill To

North Hampton Fire Department
Attn: Lieut Peter Francis
235 Atlantic Avenue
PO Box 606
North Hampton NH 03862

Ship To :

Attn: Lieut Peter Francis
235 Atlantic Avenue
PO Box 606
North Hampton NH 03862

Prices based on a quantity of 12 lights

| Quantity | Style | Description | Unit Price | Your Cost |
|----------|-------|--|------------|-----------|
| 9 | 90500 | Streamlight Survivor LED (Light Only) - Orange | 87.30 | 785.70 |

Financing options available on some turnout gear purchases. Prices quoted do not include shipping and handling. Shipping is FOB factory. This quote is based on current prices which are subject to change by the Manufacturer without notice. TERMS are NET 30 DAYS.



North Hampton
FIRE & RESCUE

235 ATLANTIC AVENUE
NORTH HAMPTON, N.H. 03862

Michael J. Tully
CHIEF OF DEPARTMENT

TEL: (603) 964-5500
FAX: (603) 964-7249
EMERGENCY: 911

To: Mr. Paul Apple
From: Chief Michael Tully
Subject: Encumbrance of Funds
Date: 6/21/2016

Please accept this request to be on the select board agenda in order to transfer \$1211.00 from FY 2015/2016 line item 1-4220-10-120 (Salary) to FY 2016/2017 line item 1-4220-10-640 (Station Maintenance).

This will allow six dining chairs to be purchased for use in the fire station.

Respectfully,

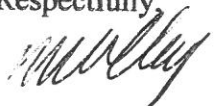

Michael J. Tully

"Quality Service for a Quality Community"

DATE 10.21.2016 P.O. DeOTE

SPECIAL INSTRUCTIONS:

Special Wash D+Se 89 or ple in Barnix for
 So, as you try to read this very small print, do you wonder if you are signing your life away? Don't worry we keep it simple. If you order something...or lots of things...we assume you want them, so we order them for you. Since we ordered them for you, we cannot cancel an order or refund a deposit. We don't take returns on mattresses and upholstery, but other in-stock items can be returned within 7 days.



Customer's Signature

NS7

Received in Good condition

Set by New

The All American Furniture Store

HUBBINGTONS

North Hampton, NH 03862 • 603-379-8989 • www.hubbingtons.com

| | |
|----------|-----------|
| DEPOSIT | |
| BALANCE | |
| DELIVERY | <i>89</i> |

SUBTOTAL

RETAIL

SELLING

TOTAL

DESCRIPTION

FINISH/COVER-FABRIC

ITEM NUMBER

WINDSOR HI-BACK



391A



391



390

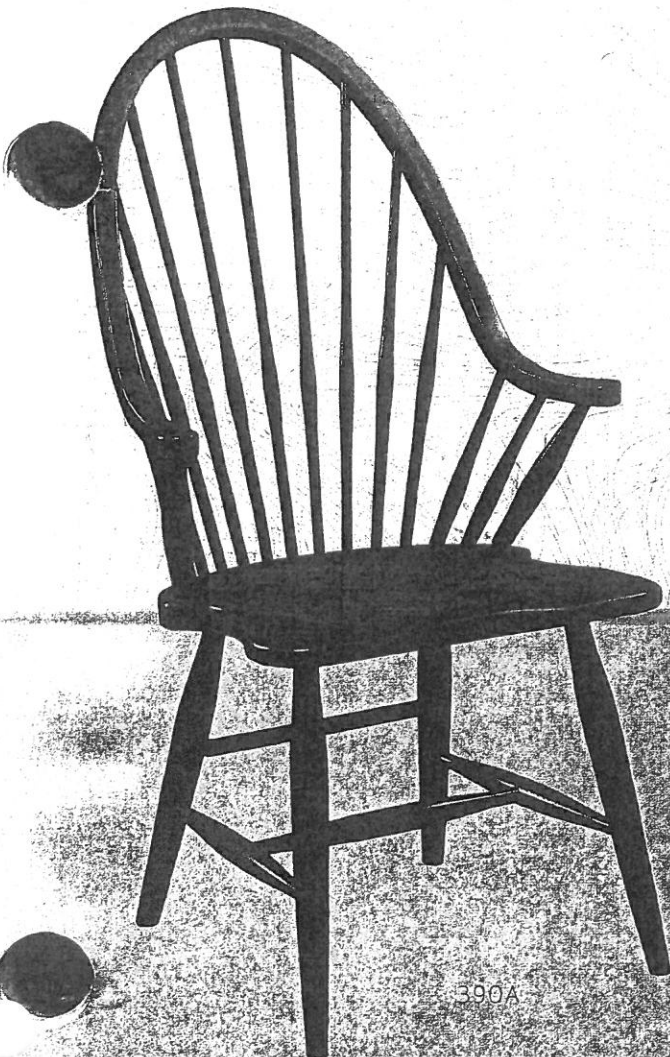

390A



390

WINDSOR HI-BACK

390/391
HI-BACK WINDSOR
SIDE CHAIR
41 1/2" H x 19 1/2" W x 22" D
17 1/2" SH x 17" SPD
Maple

390A/391A
HI-BACK WINDSOR
ARM CHAIR
41 1/2" H x 22" W x 24" D
17 1/2" SH x 17" SPD
25 1/2" AH x 18 1/2" AW
Maple

The difference between the 390 and the 391 Hi-Back Windsor Chairs is that the 391 has the detailed/turned leg design.



North Hampton
FIRE & RESCUE

235 ATLANTIC AVENUE
NORTH HAMPTON, N.H. 03862

TEL: (603) 964-5500
FAX: (603) 964-7249
EMERGENCY: 911

Michael J. Tully
CHIEF OF DEPARTMENT

To: Mr. Paul Apple
From: Chief Michael Tully
Subject: Encumbrance of Funds
Date: 6/20/2016

Please accept this request to be on the select board agenda in order to transfer \$528.00 from FY 2015/2016 line item 1-4220-10-120 (Salary) to FY 2016/2017 line item 1-4220-10-640 (Station Maintenance).

This will allow three office chairs to be purchased for use in the fire station dispatch.

Respectfully,

Michael J. Tully

"Quality Service for a Quality Community"



June 20, 2016

Town of N. Hampton
Fire Dept. - Attn: Will Taber
233 Atlantic Avenue
N. Hampton, NH

Dear Will:

Here is the pricing for the Basyx chairs:

| | List | Net Each | Total Net |
|-------------------|---------|----------|-----------|
| 3 ea BSXVL151SB11 | \$ 300. | \$ 176. | \$ 528. |

The lead-time is approximately 5 days. This pricing includes S&H, Delivery & Assembly. If you have any questions, please let me know.

Thank you for the opportunity to quote you these items!

Sincerely,

Christine Goodwin
WB Mason, Co., Inc.

Welcome to wbmason.com
Login | Register



| | |
|---------------|----------|
| SHOPPING CART | |
| 3 Items | \$629.97 |
| QUICK ORDER | CHECKOUT |

Federal Government Customers

Selected List
[Create Favorites Lists](#)

SHOP

SERVICES

SUPPORT

ORDERS

ACCOUNT CENTER

FAVORITES

Already a W.B. Mason Customer?

You have indicated that your organization already orders from W.B. Mason. Register Now with your organization's Account Number for a more customized purchasing experience. Once associated to your account you will be able to see your Account's pricing, shipping addresses, Order History, and more.

< return to search results



basyx® VL151 Series Executive High-Back Chair,
Black Leather

Item: BSXVL151SB11

- Black leather upholstery for luxurious comfort and style.
- Plush, overstuffed back and padded loop arms.
- Five-star base with casters for easy mobility.

~~\$209.99~~
EA

QTY **ADD TO CART**

Availability: **Rapid Delivery**

[enlarge image](#)



[Take a Product Tour](#)

From the Manufacturer | Powered by WEBCOLLAGE

basyx by HON VL151 Executive High-Back Chair



The basyx by HON seating collection is where quality meets value. This VL151 executive high-back chair has center-tilt with lock and tension control. SofThread leather upholstery and padded loop arms give this chair an upscale feel at a compelling price. Seat and back SofThread leather color is Black.

- Distinctive style you crave, at a fraction of the cost
- Smooth, pliable SofThread leather seating surfaces with tailored stitching detail; color is Black
- Frame and five-star base are molded from reinforced resin for increased durability
- Integrated headrest provides additional upper body support, especially when in recline
- Ergonomically contoured back provides support to the lower spine for all-day comfort
- Center-tilt mechanism rotates the seat from a point at the center to comfortably recline
- Tilt tension controls the rate and ease of recline
- Upright tilt lock secures the chair in the full upright position
- Pneumatic seat height adjustment moves the seat up and down to adapt to various body heights
- Backed by the basyx by HON Limited 5-Year Warranty



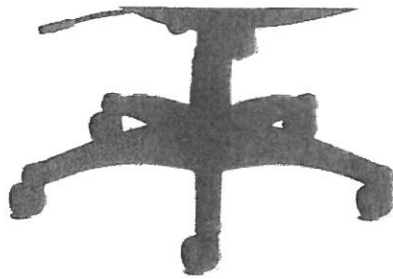

Images

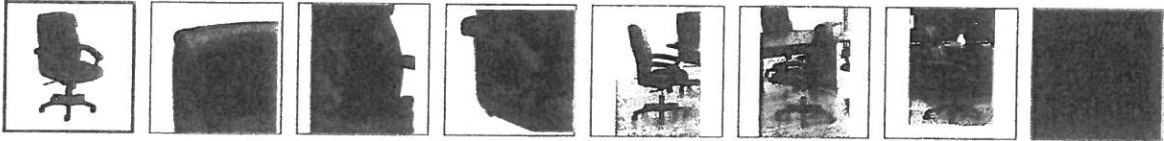

VL151



VL151 Tour

- 1 Integrated Headrest
- 2 Contoured Back
- 3 Padded Loop Arms
- 4 SofThread™ Leather Upholstery
- 5 Tilt Tension
- 6 Seat Height and Tilt Lock

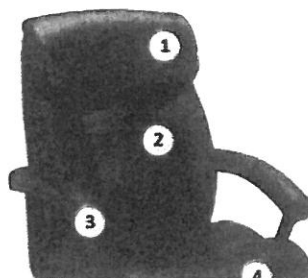

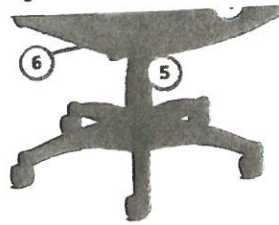

Click a feature from the list or a number in the picture to view details

Ergonomic Features

Pneumatic Seat Height Adjustment

Regulates height of chair relative to floor.

Benefits

- Properly adjusted, provides optimum, balanced support for lower back, buttocks & thighs
- Encourages adequate blood circulation to feet
- Eliminates pressure points behind knees



360 Degree Swivel

Standard on nearly every executive and task chair. The seat and back rotate in a full circle around the stem and base of the chair.

Benefits

- Allows a user to access a variety of adjacent work areas without standing up from the chair
- The greater the amount of body movement, the more the user will benefit from increased circulation and redistribution of pressure points during the workday



Center Tilt

Tilt is considered the most basic posture adjustment available. With a tilt control, the chair pivots around a fixed point—usually located directly above the pneumatic cylinder. The tilt has a 1:1 ratio; for every one inch you lean back, the front edge of the seat comes up one inch.

Benefits

- Allows for a comfortable rocking/reclining motion during meetings, phone calls, and reading activities
- The greater the amount of body movement, the more the user will benefit from increased circulation and redistribution of pressure points during the workday



Tilt Tension

This is a function of the height and weight of an individual. The taller and/or heavier the person, the need for a tighter tilt tension. The opposite for a shorter, lighter person, the lighter the control. If the Tilt Tension is set too light for an individual, when they sit in the chair, they may have the sensation of going over backwards. Conversely, if the tension is set too tight, a smaller individual may not be able to tilt the chair at all.

Benefits

- Because gravity works with the user, the chair has an enjoyable "rocking" sensation
- The greater the amount of body movement, the more the user will benefit from increased circulation and redistribution of pressure points during the workday



Tilt Lock

Locks out tilt function when chair is in upright position.

Benefits

- Tilt lock allows the user to sit in an upright position for keyboarding, while providing a comfortable rocking/reclining motion during meetings, phone calls and reading activities



Documents

VL151 Cut Sheet



[View](#) | [Download](#)

PDF, 1.77MB, 2 pages

VL151 Assembly Sheet



[View](#) | [Download](#)

PDF, 406K, 1 page

VL151 Instruction Sheet



[View](#) | [Download](#)

PDF, 49K, 1 page

VL151 Spec Sheet



[View](#) | [Download](#)

PDF, 75K, 2 pages

Product Details Description Warranty Information

| | | | |
|---------------------------------|---------|----------------------------------|------------------------|
| Arm Style: | Loop | Back Type: | High-Back |
| Base/Frame Color/Finish: | Black | Recommended Applications: | Executive & Management |
| Seat Material(s): | Leather | Series Name: | basyx VL Series |
| Upholstery Color: | Black | | |

COMPANION ITEMS



Safco® Mesh Backrest, 17-1/2w x 3-1/8d x 15h, Black
SAF7153BL9AZ

\$28.99
EA

QTY [ADD TO CART](#)
[Add To List](#)



ES Robbins® 46 x 60 Rectangle Chair Mat, Task Series AnchorBar for Carpet up to 1/4"
ESR1203219AZ

\$99.90
EA

QTY [ADD TO CART](#)
[Add To List](#)



Fellowes® Professional Series Back Support, Memory Foam Cushion, Black
FEL80376019AZ

\$59.99
EA

QTY [ADD TO CART](#)
[Add To List](#)



Kensington® Memory Foam Seat Rest, 13-1/2"w x 14 1/2"d x 2"h, Black
KMW820249AZ

\$49.99
EA

QTY [ADD TO CART](#)
[Add To List](#)

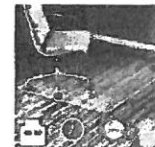

deflecto® EconoMat Anytime Use Chair Mat for Hard Floor, 45 x 53 w/Lip, Clear
DEFCM212329AZ

\$72.99
EA

QTY [ADD TO CART](#)
[Add To List](#)

Since 1898, the dedicated group at W.B. Mason has been passionate about bringing amazingly low prices, superior delivery and outstanding personal service to businesses of all sizes. From our humble beginnings in a small warehouse in Brockton, MA, we have grown to become the largest, privately owned office products dealer in the United States. We have all your workplace essentials, from office supplies and furniture, to break room and facilities maintenance. Let us be your one source for all of your office needs.

Copyright W.B. Mason. All Rights Reserved.

WhattaBargain! Clearance Zone Print Shop Brand Stores Rebate Center

[Contact Us](#) [About Us](#) [Privacy Policy](#) [Web Accessibility](#) [Terms of Use](#) [Careers](#)



[JOIN OUR MAILING LIST](#)





North Hampton
FIRE & RESCUE

235 ATLANTIC AVENUE
NORTH HAMPTON, N.H. 03862

TEL: (603) 964-5500
FAX: (603) 964-7249
EMERGENCY: 911

Michael J. Tully
CHIEF OF DEPARTMENT

To: Mr. Paul Apple
From: Chief Michael Tully
Subject: Encumbrance of Funds
Date: 6/20/2016

Please accept this request to be on the select board agenda in order to transfer \$129.99 from FY 2015/2016 line item 1-4220-10-120 (Salary) to FY 2016/2017 line item 1-4220-10-740 (Equipment).

This will allow the replacement of one computer monitor failing in the dispatch center.

Respectfully,

Michael J. Tully

"Quality Service for a Quality Community"

Try Prime

Computers > 27 inch monitor

Departments >

Your Amazon.com Today's Deals Gift Cards & Registry

Hello, Sign in

Your Account >

Try Prime >

Lists >

1

Cart

Computers Laptops > Tablets > Desktops > Monitors > Computer Accessories > PC Components > PC Gaming > All Electronics

< Back to search results for "27 inch monitor"



Viewsonic VA2446M-LED 24-Inch 1080p 5 ms LED Monitor

Share

270+ Shares

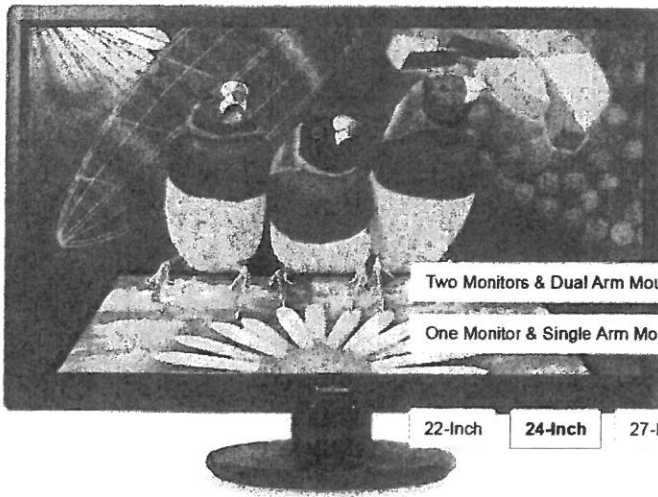

Two Monitors & Dual Arm Mount

One Monitor & Single Arm Mount

One Monitor

22-Inch

24-Inch

27-Inch

Reviews

Shipping. Details

Arrives within 2 hrs 3 mins and free pickup. Details
Gift-wrap available.

Buy new: \$129.99

Qty: 1

Yes, I want FREE Two-Day Shipping with Amazon Prime

Include 4-Year Protection for \$29.99

Include 2-Year Protection for \$9.99

Add to Cart

Turn on 1-Click ordering for this browser

Ship to:

PLYMOUTH, MA 02360

Buy used: \$99.99

Add to List

Other Sellers on Amazon

\$145.00

+ Free Shipping

Sold by: EnterComputers

Add to Cart

\$146.30

+ Free Shipping

Sold by: JF3 Technology

Add to Cart

\$147.44

+ \$9.89 shipping

Sold by: Ace Micros

Add to Cart

46 used & new from \$97.99

Have one to sell?

Sell on Amazon



FLEXIMOUNTS

Dual Monitor Mount Stand for Lcd Screens & laptops

FLEXIMOUNTS 2 in 1 Full Motion Dual Arm LCD Desk Mount Stand Fits 15-27 inch monitors

56

\$59.99

Ad feedback

Roll over image to zoom in

- Energy Star and TCO Certified
- VESA mountable 100mm x 100mm

24 new from \$129.99 20 used from \$97.99
2 refurbished from \$119.89



Top new products

Shop the latest computer accessories and gadgets on Amazon Launchpad. Shop now

Frequently Bought Together



+



Total price: \$138.48

Add both to Cart

Add both to List

One of these items ships sooner than the other. Show details

This item: Viewsonic VA2446M-LED 24-Inch 1080p 5 ms LED Monitor \$129.99

AmazonBasics DVI to DVI Cable - 6.5 Feet (2 Meters) \$8.49

Customers Who Bought This Item Also Bought

Product Description

Style: One Monitor | Size: 24-Inch

Product Description

The ViewSonic VA2446m-LED is a 24" (23.6 Vis) widescreen monitor with an LED backlight and glossy, thin-bezel design ideal for use in the home or at the office. With Full HD 1920x1080 resolution and a 10M:1 dynamic contrast ratio, the VA2446m-LED delivers stunning brightness and contrast, while a quick 5ms response time ensures crisp pictures and smooth playback. As a complete multimedia package, the display also includes a pair of integrated speakers. VGA and DVI inputs provide flexible and convenient connectivity, while a VESA-mountable design offers additional mount flexibility. With an efficient LED backlight and energy-saving Eco mode, the VA2446m-LED is an environmentally friendly display choice. In addition, a 3-year warranty, along with one of the industry's best pixel performance policies provides great value for the stylish, high-performance VA2446m-LED display.

Amazon.com

Product Description

The ViewSonic VA2446m-LED is a 24" (23.6" viewable) widescreen monitor with a LED backlight and a glossy, thin-bezel design ideal for use in the home or at the office. With Full HD 1920x1080 resolution and a 10M:1 MEGA Dynamic Contrast Ratio, the VA2446m-LED delivers stunning brightness and contrast, while a quick 5ms response time ensures crisp pictures and smooth playback. As a complete multimedia package, the display also includes a pair of integrated speakers. VGA and DVI inputs provide flexible and convenient connectivity, while a VESA-mountable design offers additional mount flexibility. With an efficient LED backlight and energy-saving Eco-mode, the VA2446m-LED is an environmentally friendly display choice. In addition, a 3-year limited warranty, along with one of the industry's best pixel performance policies provides great value for the stylish, high-performance VA2446m-LED display.

Key Features:

- 24" (23.6" viewable) widescreen LED backlit monitor; great value for small office, home office applications, corporations, government and education
- Up to 50%* power savings over a traditional CCFL 24" monitor
- 1920x1080 resolution with 16:9 aspect ratio for perfect image reproduction
- Connectivity options include DVI (with HDCP) and VGA inputs
- Multimedia enriched with integrated stereo speakers
- 100 x 100mm VESA compliant for wall mount or monitor stands
- Industry-leading pixel performance guarantee and 3-year limited warranty

What is a LED monitor?

The term "LED monitor" generally refers to a monitor with a LCD panel and a LED backlight. A typical LCD monitor uses cold cathode fluorescent lamps (CCFL) as a light source to illuminate the LCD panel. In an LED backlit monitor, white LEDs (Light Emitting Diodes) are used as the light source. Environmentally friendly LED backlights provide the following benefits:

- About 50%* less power consumption compared to a traditional CCFL monitor
- 10M:1 MEGA Dynamic Contrast Ratio
- Environmentally friendly mercury-free backlight
- Low EMI (Electro Magnetic Interference)
- Slimmer design
- Weight reduction

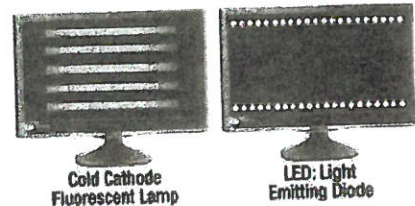

Save cash and save the planet

With its mercury-free backlight and low energy consumption, the ENERGY STAR certified VA2446m-LED saves your electricity bill. The savings of LED can add up to thousands of dollars saved for large install bases, such as big corporate buildings or schools. The savings can be as dramatic as \$20,000 in five years!

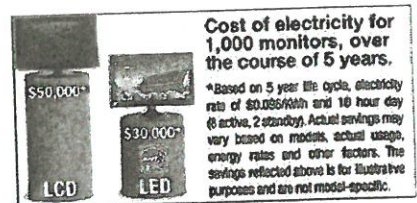

10M:1 MEGA Dynamic Contrast Ratio

Dynamic contrast ratio detects the brightness of an image, and automatically adjusts the backlight to maximize the monitor's color range and contrast. Dynamic contrast ratio technology enables the accurate reproduction of images, producing vibrant and rich visual effects.



Full HD 1080p for Superior Pixel Performance

The VA2446m-LED features a Full HD 1080p 1920x1080 resolution for unbelievable pixel-by-pixel image performance. You'll experience the most amazing clarity and detail whether it be while working, gaming, or enjoying the latest in multimedia entertainment. A 16:9 widescreen ratio minimizes eye fatigue even after hours of viewing and is perfectly compatible with multi-window viewing without toggling.

Pair it with a ViewSonic or Mac computer

One of the key advantages of the VA2446m-LED monitor is its diverse connectivity options, making it flexible to be paired with a PC or a Mac computer. Now you can hook up any ViewSonic PC as well as a MacBook or a Mac Mini to the VA2446m-LED and enjoy a widescreen with LED backlight!



Product Information

Style: **One Monitor** | Size: **24-Inch**

Technical Details

[Collapse all](#)

Additional Information

Summary

| | |
|-----------------------|-------------|
| Screen Size | 24 inches |
| Max Screen Resolution | 1920 x 1080 |

Other Technical Details

| | |
|---------------------------|--------------------------|
| Brand Name | ViewSonic |
| Item model number | VA2446M-LED |
| Operating System | N/A |
| Item Weight | 8.20 pounds |
| Product Dimensions | 8.3 x 22.5 x 15.8 inches |
| Item Dimensions L x W x H | 8.3 x 22.5 x 15.8 inches |
| Color | Black |

ASIN

B00D601UC8

Customer Reviews

991 customer

reviews

4.3 out of 5 stars

Best Sellers Rank

#283 in Computers & Accessories
(See top 100)
#48 in Computers & Accessories > Monitors

Shipping Weight

10.8 pounds (View shipping rates and policies)

Domestic Shipping

This item is also available for shipping to select countries outside the U.S.

International Shipping

This item is not eligible for international shipping. [Learn More](#)

Date First Available

June 3, 2013

Technical Specification

[Warranty \[pdf\]](#)

Warranty & Support

Amazon.com Return Policy: You may return any new computer purchased from Amazon.com that is "dead on arrival," arrives in damaged condition, or is still in unopened boxes, for a full refund within 30 days of purchase. Amazon.com reserves the right to test "dead on arrival" returns and impose a customer fee equal to 15 percent of the product sales price if the customer misrepresents the condition of the product. Any returned computer that is damaged through customer misuse, is missing parts, or is in unsellable condition due to customer tampering will result in the customer being charged a higher restocking fee based on the condition of the product. Amazon.com will not accept returns of any desktop or notebook computer more than 30 days after you receive the shipment. New, used, and refurbished products purchased from Marketplace vendors are subject to the returns policy of the individual vendor.

Product Warranty: For warranty information about this product, please [click here \[PDF\]](#)

Feedback

Would you like to update product info or give feedback on images?
Would you like to tell us about a lower price?

Sponsored Products Related To This Item (What's this?)



ViewSonic VX2457-MHD
24-inch 1080p Gaming
Monitor with 2ms, VGA,
HDMI, DisplayPort and
56
\$129.99



AllEasy 3-in-1 Mini DP
Adapter, Mini
Displayport(Thunderbolt)to
VGA DVI-HDMI Adapters
10
\$14.95

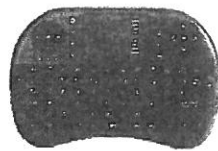

Tigervivi® 2.4GHz Mini
Wireless British Layout
Keyboard Mouse Remote
Control Fly Air Mouse With
2
\$14.68



VicTsing Gold-plated
DisplayPort(DP) Male To
VGA Female Cable
Adapter for PC Laptop
652
\$9.99



ViewSonic VA2265smh
22-Inch SuperClear MVA
LED Monitor (Full HD
1080p, HDMI/VGA,
390
\$109.99

[Ad feedback](#)



North Hampton
FIRE & RESCUE

235 ATLANTIC AVENUE
NORTH HAMPTON, N.H. 03862

Michael J. Tully
CHIEF OF DEPARTMENT

TEL: (603) 964-5500
FAX: (603) 964-7249
EMERGENCY: 911

To: Mr. Paul Apple
From: Chief Michael Tully
Subject: Encumbrance of Funds
Date: 6/21/2016

Please accept this request to be on the select board agenda in order to transfer \$2150.00 from FY 2015/2016 line item 1-4220-10-120 (Salary) to FY 2016/2017 line item 1-4220-10-571 (Equipment Maintenance).

This will allow the department to service the three sets of rescue tools it currently has in service on the apparatus. The equipment is serviced every two years.

Respectfully,

Michael J. Tully



**FIRE TECH & SAFETY
OF NEW ENGLAND INC.**

90 Progress Ave
Tyngboro, MA 01879

978-649-6800
1-800-331-7900 FAX (978) 649-6833

QUOTATION

PLEASE INDICATE THE ABOVE NUMBER WHEN ORDERING

TO **North Hampton Fire Department**
235 Atlantic Ave
North Hampton, NH 03862

| | |
|----------------|-----------------|
| QUOTATION DATE | SALESPERSON |
| 6/20/2016 | Craig Robichaud |
| INQUIRY DATE | |

| ESTIMATED SHIPPING DATE | SHIPPED VIA | F.O.B. | TERMS | |
|-------------------------|--|------------|------------|--|
| | | | Net 30 | |
| QUANTITY | DESCRIPTION | UNIT PRICE | AMOUNT | |
| | All pricing for budgeting purposes only | | | |
| | Quote is for standard service, all parts needed | | | |
| | beyond standard service are extra | | | |
| 2 | AMKUS SERVICE FOR SPREADERS | \$100.00 | \$200.00 | |
| 3 | AMKUS SERVICE FOR CUTTERS/COMBI-TOOL | \$100.00 | \$300.00 | |
| 4 | AMKUS SERVICE FOR RAMS | \$75.00 | \$300.00 | |
| 3 | AMKUS SERVICE FOR POWER UNITS | \$450.00 | \$1,350.00 | |
| | | TOTAL | \$2,150.00 | |

WE ARE PLEASED TO SUBMIT THE ABOVE QUOTATION FOR YOUR CONSIDERATION. SHOULD YOU PLACE AN ORDER, BE ASSURED IT WILL RECEIVE OUR PROMPT ATTENTION. THIS QUOTATION IS VALID FOR 30 DAYS. THEREAFTER IT IS SUBJECT TO CHANGE WITHOUT NOTICE.

QUOTED BY: FIRE TECH SAFTEY ACCEPTED _____ DATE _____

PLEASE SIGN AND RETURN A COPY WHEN ORDERING

THANK YOU!

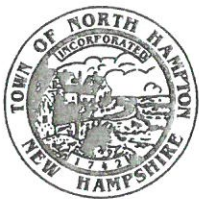

North Hampton
FIRE & RESCUE

235 ATLANTIC AVENUE
NORTH HAMPTON, N.H. 03862

Michael J. Tully
CHIEF OF DEPARTMENT

TEL: (603) 964-5500
FAX: (603) 964-7249
EMERGENCY: 911

To: Mr. Paul Apple
From: Chief Michael Tully
Subject: Encumbrance of Funds
Date: 6/20/2016

Please accept this request to be on the select board agenda in order to transfer \$18,247.50 from FY 2015/2016 line item 1-4220-10-120 (Salary) to FY 2016/2017 line item 1-4220-10-640 (Station Maintenance).

This will allow the department to purchase a commercial fire gear extractor and dryer in order to properly decontaminate fire gear.

Respectfully,

Michael J. Tully



1024 Suncook Valley Hwy., Unit 5-D
Epsom NH, 03234
TEL: 603.736.8500
www.BergeronProtectiveClothing.com

QUOTATION

No. : **200623**

Doc. Date : 06/11/2016
Payment Terms : NET30
Valid Until: 12/01/2016
Customer PO:
Salesperson : Maureen Gnecco
Page : Page 1 of 2

Bill To

North Hampton Fire Department
Attn: Lieut Peter Francis
235 Atlantic Avenue
PO Box 606
North Hampton NH 03862

Ship To :

Attn: Lieut Peter Francis
235 Atlantic Avenue
PO Box 606
North Hampton NH 03862

Pricing includes freight, delivery (with easy access), set in place, leveling, bolting, grouting (as required), made ready for utility connections by other, start-up, and operator training.

| Quantity | Style | Description | Your Cost |
|----------|---------|---|-----------|
| 1 | MWR16X5 | Milnor Model MWR16X5 35 lb Washer w/ Gear Guardian Formulas Cabinet Style 30 Programmable Formulas Includes 10 pre-programmed gear formulas 208/240/1-3 Meets all NFPA 1851 guidelines Capacity 1-2 sets (2-4 pieces) Pricing includes Installation & Delivery | 6,875.00 |
| 1 | MWR18X4 | Milnor Model MWR18X4 45 lb. Washer W/ Gear Guardian Formulas Cabinet Style 30 Programmable Formulas Includes 10 pre-programmed gear formulas 208/240/1-3 Meets all NFPA 1851 guidelines Capacity 3 Sets of Gear (6 Pieces) | 8,312.50 |
| 1 | MWR27X5 | Milnor Model MWR-27 60# Gear Washer w/Gear Guardian Formulas Cabinet Style 30 Programmable Formulas Includes 10 pre-programmed gear formulas 208/240/1-3 Meets all NFPA 1851 guidelines Capacity 4-5 Sets of Gear (8-10 Pieces) | 11,562.50 |
| 1 | BASE | 10" Heavy Duty Steel base Required with cabinet Style Washers Only | 385.00 |
| 1 | AF | Patriot Chemical Auto Feeder | |

Financing options available on some turnout gear purchases. Prices quoted do not include shipping and handling. Shipping is FOB factory. This quote is based on current prices which are subject to change by the Manufacturer without notice. TERMS are NET 30 DAYS.

From: BERGERON PROTECTIVE CLOTHING LLC
To: North Hampton Fire Department

Document No. : 200623
Doc. Date : 06/11/2016

| Quantity | Style | Description | Your Cost |
|----------|--------|---|-----------|
| 1 | 2723-5 | Option: Add \$280 Includes installation of auto feeder, parts, service, and labor for life. Requires use of Patriot Chemical brand detergents. The Auto Feeder Dispenses the proper detergent, based on the wash program selected, in the proper dose, and at the proper time in the cycle. Recommended. Patriot Chemical FireHouse Detergent - 5 Gallon Pail Option: Add \$120 | |

Financing options available on some turnout gear purchases. Prices quoted do not include shipping and handling. Shipping is FOB factory. This quote is based on current prices which are subject to change by the Manufacturer without notice. TERMS are NET 30 DAYS.

Lt.,

Find below the pricing and literature on the Milnor extractor I discussed with you. I will forward the Staber drying unit info after this has been sent.

1- Milnor 35lb Cabinet Gear Washer/Extractor p/n MWR16X5

Price: \$7395.00

Option: Milnor 45lb Cabinet Gear Washer/Extractor p/n MWR18X4 price: \$8850.00

Base for both washers. Price: \$450.00

Option: H-M Drain Trough 3'x 16"x 12' Price: \$565.00

W/Sump Hole Price: \$725.00

Staber 6 Gear Electric Drying Cabinet p/n IDC-2200-6-PPE with following: 3- Coat Hangers

2- Glove Racks

1- Boot Hanger

1- Multi Purpose Hanger

1- ~~Hose~~ Drying Shelf

Price: \$8150.00

Above prices include estimated freight, delivery(with easy access), set in place, leveling, bolting, grouting(as required), made ready for utility connections by other, start up, and operator training.

Current users: OOB Fire Department, York Beach Fire Dept, Litchfield NH Fire Dept., Bridgton Me Fire Dept, Windham Me Fire Dept, Standish Fire Dept, Poland Me Fire Department, Wells Me Fire Dept, Kennebunk Me Fire Dept. to name a few.

If you have any questions, please let me know. I can have the local representative, Gerry Guertin, stop by and speak with you and make recommendations if you like.

Thank you for the opportunity, we really appreciate the chance to work with you. Have a safe weekend!

Willie

Willie Burk

